



abiosus e.V.

Non-Profit Association for the Advancement of Research on Renewable Raw Materials

4th Workshop on Fats and Oils as Renewable Feedstock for the Chemical Industry

**March 20-22, 2011
Karlsruhe, Germany**

in Cooperation with:

Karlsruhe Institute of Technology (KIT)

German Society for Fat Science (DGF)

Agency of Renewable Resources (FNR)

Deutsche  Gesellschaft für Fettwissenschaft e.V.

Karlsruhe Institute of Technology



Scientific and Organizing Committee

Jürgen O. Metzger, *abiosus* e.V., and University of Oldenburg, Germany

Michael A. R. Meier, Karlsruhe Institute of Technology (KIT), Germany

Acknowledgement

Financial Support by the German Federal Ministry of Nutrition, Agriculture and Consumer Protection (BMELV) is gratefully acknowledged.

Content

Program	5
Poster	12
Abstracts of lectures	17
Abstracts of posters	54
List of participants	100

Program

Lectures and Posters

Sunday, March 14, 2010

Registration

Registration will be opened from 13:00 - 19:00

- 15.30 **Welcome and Opening**
- Jürgen O. Metzger, *abiosus* e.V.
- Klaus Schurz, President of German Society for Fat Science
- Stefan Bräse, Dean of Faculty of Chemistry and Biosciences, KIT
- Michael A. R. Meier, KIT
-
- 16.00 – 18.00 *First Session*
- Chair: Michael A. R. Meier*
-
- 16:00 – 16:30 **Selective Transformation of Biomass and Biogenic Platform Molecules (M)**
- L1 Walter Leitner, RWTH Aachen, Germany
-
- 16.30 – 17.00 **Determining the Greenness of Chemical Syntheses (M)**
- L2 Marco Eissen, Ganderkesee, Germany
-
- 17.00 – 17.30 **Engineered Lipids Produced by Microbes and their Use in Biobased Materials (M)**
- L3 Richard Gross, Polytechnic University, Brooklyn, NY, USA
-
- 17.30 – 18.00 **Novel Bio-based Plastics, Composites and Coatings from Agricultural Oils and By-products (M)**
- L4 Richard Larock, Iowa State University, Ames, IA, USA
-
- 18.00 – 20.30 **Poster Session and Opening Mixer.**
- Posters will be displayed until the end of the workshop

- (M) Main Lecture 30 min including discussion
(D) Discussion Lecture 20 min including discussion

Monday, March 21, 2011

8.30 – 10.00 *First morning session*

Chair: Walter Leitner

8.30 – 9.00
L5 **Monomers and commodity chemicals from oleochemicals (M)**
David J. Cole-Hamilton, Ruben Duque, Ronan le Goff, Marc Furst, Juma Mmongoyo, University of St. Andrews, U. K., and Quintino Mgani, University of Dar-es-Salaam, United Republic of Tanzania

9.00 – 9.20
L6 **Linear Semicrystalline Polycondensates from Plant Oils (D)**
Florian Stempfle, Dorothee Quinzler, Ilona Heckler, Stefan Mecking, Universität Konstanz, Germany

9.20 – 9.40
L7 **New ways to polymerize castor oil derived platform chemicals (D)**
Oliver Kreye, Michael A. R. Meier, Karlsruhe Institute of Technology, Karlsruhe, Germany

9.40 – 10.00
L8 **Catalyst recycling in carbonylation reactions of fatty acids (D)**
Andreas J Vorholt, Arno Behr, TU Dortmund, Germany

10.00 – 10.30 **Coffee break**

10.30 – 12.20 *Second morning session*

Chair: Mats K. G. Johansson

10.30 – 11.00
L9 **Green Approaches toward Plant-derived Monomers and Polymers via Thiol-Ene Click Chemistry (M)**
Gerard Lligadas, Cristina Lluch, Rodolfo J González, Enrique del Rio, Juan C. Ronda, Marina Galià, Virginia Cádiz, University Rovira i Virgili, Tarragona, Spain

11.00 – 11.20
L10 **Synthesis of biobased polyols by click chemistry from vegetable oils and their derivatives (D)**
Sylvain Caillol, Myriam Desroches, Bernard Boutevin, Remi Auvergne, ENSCM, Montpellier, France

11.20 – 11.40
L11 **Branched macromolecules from plant oils: Towards greener strategies (D)**
Lucas Montero de Espinosa, Michael A. R. Meier, Karlsruhe Institute of Technology, Karlsruhe, Germany

- 11.40 – 12.00
L12 **Selectivity in Sorption and Hydrogenation of FAMES and Triglycerides on MFI Zeolites (D)**
An Philippaerts¹, Sabine Paulussen,¹ Stuart Turner,² Oleg I. Lebedev,² Gustaaf van Tendeloo,² Pierre Jacobs,¹ Bert Sels,¹ ¹K.U.Leuven, Heverlee, Belgium; ² University of Antwerp, Antwerpen, Belgium
- 12.00 – 12.20
L13 **Electrochemical Conversion of Fatty Acids (D)**
Hans J. Schäfer, University of Münster, Münster, Germany
- 12.20 – 14.00 **Lunch break**
- 14.00 – 15.40 *First afternoon session*
Chair: Richard Gross
- 14.00 – 14.30
L14 **Optimizing wax ester production in oil seed-crops (M)**
Ivo Feußner, University of Göttingen, Germany
- 14.30 – 14.50
L15 **Continuous Production of 1,3-Propanediol Using Waste Glycerol with Clostridium Beijerinckii NRRL B-593 Immobilized on Glass Beads and Glass Rushing Rings (D)**
Nuri Azbar, Mine Gungormusler, Cagdas Gonen, Ege University, Izmir, Turkey
- 14.50 – 15.20
L16 **Process Development and Environmental Assessment of Chemoenzymatic One-Pot Processes (M)**
Harald Gröger, University of Erlangen, Germany
- 15.20 – 15.40
L17 **Chemical Modifications of Sterculia foetida Oil to Highly Branched Products (D)**
Louis Daniel¹, H. H. van de Bovenkamp¹, Teddy Buntara¹, Siti Maemunah¹, Gerard Kraai¹, I. G.B.N. Makertihartha², Robert Manurung², Hero J. Heeres¹, ¹ University of Groningen, Netherlands; ² Bandung Institute of Technology, Indonesia
- 15.40 – 16.10 **Coffee break**

- 16.10 – 18.10 *Second afternoon session*
- Chair: Dean Webster*
- 16.10 – 16.40 **Latent Heat Characteristics of Oleochemical Carbonates and their Eutectic Mixtures as Potential Phase Change Materials (M)**
L18 Jim Kenar, USDA-ARS-NCAUR, Peoria, IL, USA
- 16.40 – 17.00 **Auto-organization and polymorphism properties of pure short and medium chain monoglycerides and glycerol carbonate esters (D)**
L19 Romain Valentin, Zéphirin Mouloungui, INRA, France
- 17.00 – 17.30 **What is Meant by 'Bio'? The Use of Renewable Raw materials for Lubricants Business (M)**
L20 Rolf Luther, Fuchs Europe Schmierstoffe GmbH, Mannheim, Germany
- 17.30 – 17.50 **New heterogeneous catalysts for the production of biodegradable lubricants (D)**
L21 Federica Zaccheria,¹ Nicola Scotti,² Nicola Scotti,³ Gabriele Ricchiardi,³ Nicoletta Ravasio,¹ Rinaldo Psaro,¹ ¹ CNR ISTM, Italy; ² CNR ISTM; ³ NisLabVCO, Italy
- 17.50 – 18.10 **Novel Lipid-Modified Carbohydrates – Potential Oil Soluble Antioxidants and Gelators (D)**
L22 Sukhendu Nandi, Hans-Josef Altenbach, Manfred P. Schneider, Bernd Jakob, Karsten Lange, Rachid Ihizane, Bergische Universität Wuppertal, Germany
- 19.30 *Conference Dinner*
- Renaissance Karlsruhe Hotel**

Tuesday, March 22, 2011

8.30 – 10.20 *First morning session*

Chair: Richard Larock

8.30 – 9.00
L23 **Biodegradable Polymers for Packaging Applications (M)**
Andreas Künkel, BASF, Ludwigshafen, Germany

9.00 – 9.30
L24 **Fatty Acid Methyl Esters as Reactive Diluents in Thermoset Coatings (M)**
Mats K. G. Johansson, KTH, Stockholm, Sweden

9.30 – 9.50
L25 **Biohybrid Silver Nanocomposites as Antimicrobial Surface Coating Materials (D)**
Deewan Akram,^{1,2} Eram Sharmin,¹ Sharif Ahmad,¹
¹Materials Research Lab., Dept. of Chemistry, Jamia Millia Islamia, New Delhi, India; ²Dept. of Chemistry, Faculty of Science, Jazan University, Jazan, Kingdom of Saudi Arabia

9.50 – 10.20
L26 **Production of polyglycerol from renewable sources (M)**
Marc A. Dubé, University of Ottawa, Canada

10.20 – 11.00 **Coffee Break**

11.00 – 12.30 *Second morning session*

Chair: Marc A. Dubé

11.00 – 11.30
L27 **Glycerol as solvent: a new tool for the design of environmentally friendly catalytic processes (M)**
F. Jerome, M. Delamplé, J. Barrault; CNRS-LACCO, Poitiers, France, and J.P. Douliez, BIA-INRA, Nantes, France

11.30 – 11.50
L28 **Glycerol/Water Phase as Green Reaction Media for Hydrophobic Bioactive Chelating (D)**
Zéphirin Mouloungui, Bachar Zebib, University of Toulouse, France

11.50 – 12.10
L29 **Acid catalyzed dehydration of glycerol to acrolein (D)**
Andreas Martin, Hanan Atia, Udo Armbruster, Leibniz-Institut für Katalyse e.V, Rostock, Germany

12.10 – 12.30 L30	New isomerizing transformations with unsaturated fatty acids (D) Lukas J. Gooßen, <u>Dominik M. Ohlmann</u> , Technische Universität Kaiserslautern, Kaiserslautern/Germany; Markus Dierker, Care Chemicals Technology, Cognis GmbH, Düsseldorf/Germany
12.30 – 14.00	Lunch break
14.00 – 16.00	<i>Afternoon session</i> <i>Chair: Harald Gröger</i>
14.00 – 14.30 L31	Epoxidized Sucrose Ester Resins: A New Highly Functional Biobased Epoxy Resin for Thermosets (M) <u>Dean Webster</u> , North Dakota State University, Fargo, ND, USA
14.30 – 14.50 L32	Epoxidation of methyl oleate over Ti(IV) -grafted silica catalysts with hydrogen peroxide (D) <u>Elena Gavrilova</u> , ¹ Matteo Guidotti, ¹ Rinaldo Psaro, ¹ Anne Galarneau, ² Nicoletta Ravasio, ¹ ¹ Università degli studi di Milano, Milano, Italy; ² Institut Charles Gerhardt Montpellier, France
14.50 – 15.10 L33	Synthesis of Oleochemical Derivatives via Zinc (II) perchlorate hexahydrate Catalysed Ring Opening Reactions and Co-halogenation on Olefinic Fatty Substrates (D) <u>Sukhprit Singh</u> , Guru Nanak, Avinash Bhadani, Raman Kamboj, Bhupinderpal Singh, Dev University, Amritsar, India
15.10 – 15.40 L34	Production, Technologies and Applications of Fatty Alcohols (M) <u>Klaus Noweck</u> , Brunsbüttel, Germany
15.40	Poster Award and Closing Remarks Best Poster Award Award committee: Ivo Feußner, Jim Kenar, Gerard Lligadas Closing remarks Michael A. R. Meier
16.00	End of Workshop

Posters

- P1 **Synthesis and characterization of esters derived from ricinoleic acid and evaluation of their low temperature properties**
Nadia Salih,¹ Jumat Salimon,¹ Emad Yousif,² ¹School of Chemical Sciences & Food Technology, Faculty of Science and Technology, Universiti Kebangsaan Malaysia; ² Department of Chemistry, College of Science, Al-Nahrain University, Baghdad, Iraq.
- P2 **Saponification Method for Carotene Extraction from Red Palm Oil**
Yousef Fazli, Parisa Kermani, Islamic Azad University- Arak Branch, Arak, Islamic Republic of Iran
- P3 **¹³C NMR AND ¹H NMR SPECTROSCOPIC ANALYSIS OF ADANSONIA DIGITATA, ALBIZIA LEBBECK AND DANIELLIA OLIVERI OILS**
Habeelat O. Adubiaro,¹ Olorunfemi O. Olaofe,² Emmanuel T. Akintayo,² Cecilia O. Akintayo,² ¹Science Technology Department, Federal Polytechnic, Ado – Ekiti. Nigeria; Chemistry Department, University of Ado – Ekiti, Ado – Ekiti . Nigeria.
- P4 **Renewable Gemini Cationic Surfactants: Synthesis and Evaluation of their Surface Properties**
Avinash Bhadani and Sukhprit Singh, Department of Chemistry, Guru Nanak Dev University, Amritsar, India.
- P5 **Modelling of critical fluids process for adding value and functionality to sunflower oil.**
Muhammad Baig¹, Regina Santos², Steve Bowra³, Daniel Pioch¹, ¹CIRAD-Persyst, 34398 Montpellier, Cedex 5, France; ²Department of Chemical Engineering, University of Birmingham, UK; ³ Phytatec UK Limited, UK
- P6 **Effect of harvest periods on some properties of olive oils obtained from several olive varieties**
Ayhan Dağdelen¹, Gülendem Tümen², Mehmet Musa Özcan³, Ekrem Dündar², ¹ Vocational High School, Food Technology, Balıkesir University Bandırma-Balıkesir; ² Department of Biology, Faculty of Science and Education, Balıkesir University Bandırma-Balıkesir; ³ Department of Food Engineering, Faculty of Agriculture, University of Selçuk, Konya, Turkey
- P7 **Composition and characteristics of some seed oils**
Ahmet S. Erol¹, Mehmet M. Özcan², Fatih Er¹, M.Uğur Yıldız³
¹ Selçuk University, Cumra High Educational College, 42500 Cumra-Konya/ Turkey; ² Department of Food Engineering, Faculty of Agriculture, Selçuk University, 42031 Konya-Turkey; ³ Open and distance education faculty İstanbul University Centre Campus, Beyazıt/Eminönü-İstanbul

- P8 **Photo curable castor oil based highly hydrophobic coatings**
Yusuf Mülazim, Emrah Çakmakçı, Memet Vezir Kahraman, Nilhan Kayaman Apohan, Marmara University, Department of Chemistry, Istanbul/Turkey
- P9 **PHYSICO CHEMICAL AND FATTY ACIDS COMPOSITION OF SOME LEGUME SEED OILS**
Henry Niyi Ogungbenle, O. Olaofe, B. E. Akhadelor, A. O. Idris, O. V. Omojola, O. T. Omotehinse, O. A. Ogunmodede, University of Ado-Ekiti, Nigeria
- P10 **Synthesis of β -Amino Alcohols from 10,11-Epoxy Methyl Undecanoate**
Raman Kamboj, Sukhprit Singh, Department of Chemistry, Guru Nanak Dev University, Amritsar, India
- P11 **Simulation of Fatty Acid Esterification Using Reactive Distillation Process for Biodiesel Production**
Ratna Dewi Kusumaningtyas^{1,2}, Mauro Banchemo¹, Arief Budiman², Giuseppe Gozzelino¹, ¹Dipartimento di Scienza dei Materiali e Ingegneria Chimica, Politecnico di Torino, Torino, Italy; ²Chemical Engineering Dept., Universitas Gadjah Mada, Yogyakarta, Indonesia
- P12 **Thiol-ene vs. ADMET: a complementary approach to fatty acid-based biodegradable polymers**
Oğuz Türünç^{1,2}, Michael A.R. Meier², ¹Hochschule Emden/Leer, Emden, Germany; ²KIT, Karlsruhe, Germany
- P13 **Novel Gemini Surfactants Based on Hydroxycarboxylic Acids**
Rachid Ihizane, Hans-Josef Altenbach, Manfred P. Schneider, Bernd Jakob, Karsten Lange, Sukhendu Nandi, Bergische Universität Wuppertal, Wuppertal, Germany
- P14 **Regioselective synthesis of β -aryl- or β -amino-substituted aliphatic esters via rhodium-catalyzed double bond migration / conjugate addition cascades**
Lukas J. Gooßen and Dominik M. Ohlmann, Technische Universität, Kaiserslautern, Germany; Markus Dierker, Care Chemicals Technology, Cognis GmbH, Düsseldorf, Germany
- P15 **Aminolysis of glycerol carbonate in hydroorganic and organic medium**
Bassam Nohra, Laure Candy, Zéphirin Mouloungui, Yann Raoul, University of Toulouse, France
- P16 **Functionalization of fatty compounds via cross-metathesis and palladium catalyzed C-H activation**
Marc von Czapiewski¹, Oliver Kreye², Michael A.R. Meier²
¹University of Potsdam, Karl-Liebknecht-Straße 24-25, Potsdam, Germany
² KIT, Institute of Organic Chemistry, Karlsruhe, Germany

- P17 **Continuous production of 1,3-Propanediol using raw glycerol with immobilized *Clostridium beijerinckii* NRRL B-593 in comparison to suspended culture**
Mine Gungormusler, Cagdas Gonen, and Nuri Azbar, Bioengineering Department, Faculty of Engineering, Ege University, 35100 Bornova, Izmir, Turkey
- P18 **Sustainable production of plant-based plasticizers**
S.C. Chua, J. Jimma, Z. Guo and X. Xu
 Department of Molecular Biology, Aarhus University, Denmark
- P19 **Novel Polyglycerol-based Stimuli-responsive Hydrogels from Renewable Sources**
Somaieh Salehpour and Marc A. Dubé, Department of Chemical and Biological Engineering, University of Ottawa, Ottawa, ON, Canada
- P20 **Novel polymeric materials derived from appropriately modified vegetable oils**
Carla Vilela, Armando Silvestre, Alessandro Gandini
 CICECO/Chemistry Department, University of Aveiro, Aveiro, Portugal
- P21 **Production of Microbial Lipids from Low-Cost Carbon Sources with the Yeast *Cryptococcus curvatus***
Ina Hein, Ines Schulze, Anke Neumann, Christoph Syldatk
 KIT, Institute of Process Engineering in Life Sciences, Karlsruhe, Germany
- P22 **Design of Ru-Zeolites for Hydrogen-free Production of Conjugate Linoleic Acids and Conjugated Oils**
An Philipaerts¹, Steven Goossens¹, Jan Geboers¹, Moniek Tromp², Stuart Turner³, Gustaaf van Tendeloo², Pierre Jacobs¹, Bert Sels¹, ¹K.U.Leuven, Heverlee, Belgium; ² TU München, Germany; ³ University of Antwerp, Belgium
- P23 **Catalytic hydrogenolysis of glycerol with in situ production of hydrogen**
 Stijn Van de Vyver¹, Els D'Hondt¹, Stuart Turner², Gustaaf Van Tendeloo², Lars Giebeler,³ Pierre Jacobs¹, Bert Sels¹, ¹K.U.Leuven, Heverlee, Belgium; ² University of Antwerp, Antwerpen, Belgium; ³Leibniz-Institute for Solid State and Materials Research, Dresden, Germany
- P24 **A New Biomedical Materials Platform Based on Natural Macrolactones**
Inge van der Meulen, Erik Gubbels, Rob Duchateau, Cor E Koning, Andreas Heise, Eindhoven University of Technology, Eindhoven, Netherlands
- P25 **Alpha olefins from fatty acids**
 Frits van der Klis, Jérôme Le Nôtre, Rolf Blaauw, Jacco van Haveren, Daan S. van Es, Wageningen UR Food & Biobased Research, Business Unit Biobased Products, Wageningen, The Netherlands
- P26 **Oxidation of tensidic alcohols to their corresponding carboxylic acids via Au-based catalysts**
Katharina Heidkamp¹, Ulf Prüße¹, Klaus-Dieter Vorlop¹, Nicolle Schwarz²
¹Johann Heinrich von Thünen-Institut (vTI), Braunschweig, Germany;
² Clariant Produkte (Deutschland) GmbH, Germany

- P27 **Catalytic Oxidation of fatty alcohol ethoxylates in a trickle-bed reactor**
Mehmet Aytemir, Ulf Prüße, Klaus-Dieter Vorlop, Nicolle Schwarz
¹Johann Heinrich von Thünen-Institut (vTI), Braunschweig, Germany;
² Clariant Produkte (Deutschland) GmbH, Germany
- P28 **Continuous transesterification of glycerol with diethyl carbonate using supported hydrotalcites as catalysts**
Mayra G. Álvarez¹, Martina Plíšková¹, Anna M. Segarra¹,
 Francesc Medina¹, François Figueras², ¹Department d'Enginyeria Química,
 Universitat Rovira i Virgili, Tarragona, Spain ²Institut de Recherches sur la
 Catalyse du CNRS, Villeurbanne, France
- P29 **Shape-memory polyurethanes synthesized from castor oil derivatived polyols via metathesis**
E. del Río¹; G. Lligadas¹, V. Cádiz¹; M. Galiá¹; J. C. Ronda¹; M. A. R. Meier²
¹Dept. of Analytical and Organic Chemistry, Rovira i Virgili University,
 Tarragona Spain; ² KIT, Institute of Organic Chemistry, Karlsruhe, Germany
- P30 **Dimethyl 1,19-nonadecandioate – a key compound to bio-based monomers**
 G. Walther¹, J. Deutsch¹, A. Martin¹, F.-E. Baumann², D. Fridag³, A. Köckritz¹,
¹Leibniz-Institut für Katalyse e. V. an der Universität Rostock, Rostock, Germany;
²Evonik Degussa GmbH, High Performance Polymers, Marl, Germany; ³Evonik
 Oxeno GmbH, Marl, Germany
- P31 **BIO-BASED POLYURETHANES FROM FATTY ACIDS**
 Aurélie Boyer, Vithoba D. Palaskar, Thomas Lebarbé, Lise Maisonneuve, Eric
 Cloutet, Benoît Gadenne, Carine Alfos, Henri Cramail, Université de Bordeaux,
 France
- P32 **EPOXIDIZED Plukenetia conophora oil BASED THIOL – ENE COATINGS**
Cecilia O. Akintayo, Michael A. R. Meier, KIT, Karlsruhe, Germany
- P33 **Fermentative utilisation of crude glycerol from rapeseed oil hydrolysis for the production of dihydroxyacetone**
S. Wiesen, N. Tippkötter, R. Ulber, Institute of Bioprocess Engineering, University
 of Kaiserslautern, Germany
- P34 **Lowering the Boiling Curve of Biodiesel using Cross-metathesis**
Rowena E. Montenegro, Michael A. R. Meier, KIT, Karlsruhe, Germany
- P35 **Lipase-catalyzed Acylation of Microbial Sophorolipids**
V. K. Recke¹, M. Gerlitzki², R. Hausmann², C. Syldatk², V. Wray³, S. Lang¹
¹Institute of Biochemistry and Biotechnology, TU Braunschweig; ² Technical
 Biology, Karlsruhe Institute of Technology (KIT); ³Helmholtz Centre of Infection
 Research, Braunschweig, Germany
- P36 **RuO₄ Catalytic Oxidative Cleavage of Oleic Acid under Ultrasonic Irradiation**
Nicolas Oget, Sandrine Rup, Eric Meux, Michèle Sindt, Michel Schneider,
 University of Metz, Metz, France

- P37 **Continuous Enzymatic Transesterification of Soybean Oil**
Tomas Vlcek, Jiří Hetflejš², Stanislav Šabata², Gabriela Kuncová², Jan Sýkora²,
¹SYNPO, a.s., Pardubice, Czech Republic; ² Chemical Process Fundamentals
(ICPF), Academy of Sciences, Czech Republic
- P38 **Moving toward desymmetrization of a glycerol derivative**
Gemma Villorbina, Marc Escribà, Jordi Eras, Mercè Balcells, Ramon Canela,
University of Lleida, Lleida, Spain
- P39 **Chemo-enzymatic epoxidation of fatty acids and triacylglycerides from various plant oils**
Paula Carrillo, Fabian Haitz, Thomas Hirth, Steffen Rupp, Susanne Zibek,
Fraunhofer IGB Stuttgart, Stuttgart, Germany
- P40 **Ruthenium Ruptures Rubber**
Stefanie Wolf, Herbert Plenio, TU Darmstadt, Darmstadt, Germany
- P41 **Living ROMP of partially renewable monomers**
Hatice Mutlu^{1,2}, Michael A. R. Meier², ¹ Hochschule Emden/Leer, Emden,
Germany; ²KIT, Karlsruhe, Germany
- P42 **ADMET polymerization of castor oil based aliphatic polycarbonates and polyester carbonates**
Hatice Mutlu^{1,2}, Michael A. R. Meier², ¹ Hochschule Emden/Leer, Emden,
Germany; ²KIT, Karlsruhe, Germany
- P43 **Renewable polyethylene mimics derived from castor oil**
Oguz Türüncü^{1,2}, Michael A. R. Meier², ¹ Hochschule Emden/Leer, Emden,
Germany; ²KIT, Karlsruhe, Germany
- P44 **Novel Materials From Renewables via Small Building Blocks with Considerable Potential: O-acylated Hydroxy Carboxylic Acid Anhydrides – Selected Highlights**
Karsten Lange, Bernd Jakob, Hans Josef Altenbach, Manfred Schneider, Rachid Ihizane, Sukhendu Nandi, Bergische Universität Wuppertal, Germany
- P45 **Hydrothermal cracking of unsaturated fatty acids**
Sarah Endisch, Gerd Unkelbach, Rainer Schweppe
Fraunhofer Institut für Chemische Technologie (ICT), 76327 Pfinztal, Germany
- P46 **Methylesters of Linseed oil Fatty Acids Modified with Dicyclopentadiene as Raw Material for Synthesis of Unsaturated Polyester Resins**
Tomas Vlcek, Luboš Víšek, Michal Pokorný, SYNPO, a.s., Pardubice, Czech Republic

Abstracts

Part 1: Lectures

Selective Transformation of Biomass and Biogenic Platform Molecules: Challenges and Opportunities

Walter Leitner

Institut für Technische und Makromolekulare Chemie, RWTH Aachen, Germany
leitner@itmc.rwth-aachen.de

The limitation of fossil resources and the global efforts to reduce anthropogenic carbon dioxide emissions demand innovative strategies for sustainable production of fuels and chemicals from renewable raw materials.[1] The conversion of biomass to valuable products can be envisaged via a set of platform molecules that constitute the key intermediates for molecular diversity by selective further transformations. Whereas many efforts focus on production processes for such platform molecules, their true potential for further conversions remains largely unexplored. In particular, this relates to the opportunity to develop potential supply chains by taking the desired product properties as starting points and define possible production pathways in analogy to the principles of retrosynthetic analysis of organic chemistry.[2]

To apply this strategy for future sustainable conversion of the biogenic feedstock, the development of novel catalytic methodologies for highly selective transformations in combination with an integrated product separation is of utmost importance. The present contribution exemplifies this for the efficient and highly selective conversion of selected biomass-derived platform chemicals using multifunctional molecular catalyst systems that were developed by rational analysis of the molecular pathways in the complex reaction networks. Multiphase catalysis is discussed for the implementation of the different transformation routes into flexible production schemes.

[1] for example see: a) G. W. Huber, S. Iborra, A. Corma, *Chem. Rev.* 2006, 106, 4044. b) A. Corma, S. Iborra and A. Velty, *Chem. Rev.* 2007, 107, 2411.

[2] F.M.A. Geilen, B. Engendahl, A. Harwardt, W. Marquardt, J. Klankermayer, W. Leitner, *Angew. Chem. Int. Ed.* 2010, 49, 5510.

Determining the Greenness of Chemical Syntheses

Marco Eissen,¹ Tobias Brinkmann,² Jens Zotzel³

¹Gymnasium Ganderkesee, Am Steinacker 12, 27777 Ganderkesee, Germany

²ifu Hamburg GmbH, Max-Brauer-Allee 50, 22765 Hamburg, Germany

³N-Zyme BioTec GmbH, Riedstrasse 7, 64295 Darmstadt, Germany

marco.eissen@web.de

In his paper [1] J. Andraos addresses editors as well as reviewers with a conclusion that is worth reading and which advises that claims of “greenness” or synthetic efficiency need to be backed up with some kind of metrics analysis. While yield and atom economy of syntheses are readily available data, the determination e.g. of the global warming potential of a production process requires a lot more information. Hence, the choice of the metric to be determined depends on

- what is the aim of an assessment; which conclusions will have to be drawn from an examination

- data availability

- time demand for data mining and examination

Corresponding tools for different application areas are available. While the software EATOS [2] gives support in synthesis design by calculating mass balances and first semi-quantitative assessments concerning toxicological effects etc., the Eco-efficiency analysis [3] offers additional features e.g. regarding the aggregation of results and economic considerations. The software Umberto® [4] in combination with the life cycle assessment database ecoinvent [5] can perform a full life cycle assessment with various assessment methods, e.g. Ecoindicator 99.

We would like to present different assessment procedures by considering some case studies. One case study concerns the valorisation of olive leaves which result from the harvest of olives. Meaning, besides the isolation of olive oil from olives, another chemical can be extracted from waste leaves.

As EATOS is the easiest tool to apply and since it offers an immediate access for newcomers, its use will be presented exemplarily.

[1] J. Andraos, Global Green Chemistry Metrics Analysis Algorithm and Spreadsheets: Evaluation of the Material Efficiency Performances of Synthesis Plans for Oseltamivir Phosphate (Tamiflu) as a Test Case, *Org. Process Res. Dev.* 2009, 13, 2, 161-185.

[2] M. Eissen, J. O. Metzger, Environmental Performance Metrics for Daily Use in Synthetic Chemistry, *Chem. Eur. J.* 2002, 8, 16, 3580-3585.

[3] P. Saling, A. Kicherer, B. Dittrich-Krämer, R. Wittlinger, W. Zombik, I. Schmidt, W. Schrott, Eco-efficiency analysis by BASF - The Method, *Int. J. LCA* 2002, 7, 4, 203-218.

[4] Umberto 5.5, 2010, IFU, Hamburg.

[5] ecoinvent Centre, ecoinvent data v2.0, Swiss Centre for Life Cycle Inventories, Duebendorf, Switzerland, www.ecoinvent.org.

Engineered Lipids Produced by Microbes and their Use in Biobased Materials

Richard A. Gross, Polytechnic Institute of NYU, United States
rgross@poly.edu

ω -Hydroxyfatty acids are a new class of biobased monomers and chemical intermediates. They can be converted to surfactants, emulsifiers, cosmetic ingredients, fragrances, and more. However, previous to our work, ω -hydroxyfatty acids proved difficult and expensive to prepare by traditional organic synthesis, precluding their use in commodity materials. Here we report the identification and elimination of 16 genes from the diploid yeast *Candida tropicalis* genome, to engineer a strain capable of producing commercially viable yields of ω -hydroxyfatty acids. For example, after reintegration of a P450 and process optimization, volumetric yields higher than 150 g/L of 14-hydroxytetradecanoic acid was produced using methyl myristate as substrate.

A simple method was developed to prepare from *Candida tropicalis* fermentations 14-hydroxytetradecanoic acid in high purity (>99.95%). This monomer was converted to poly(14-hydroxytetradecanoic acid) ($T_m = 93$ degC, $M_w = 160\ 000$, $PDI = 2.3$) using $Ti(C_3H_7O)_4$ as catalyst (200 degC, 2 h under N_2 , 220 degC, 4 h under vacuum [<0.1 torr]). After compression molding, tensile tests showed that the polymer has a Young's modulus of 419 Mpa and elongation to break of 729%. Reactive blending of poly(ω -hydroxyfatty acids) with Natureworks PLA produced bioplastics with very good strength and ductility. *Candida tropicalis* was also used to convert oleic acid to 1,18-cis-9-octanedecenedioic acid (oleic diacid). Biobased functional polyesters were synthesized via lipase (*Candida antarctica* Lipase B, CALB) catalyzed polycondensations of oleic diacid with glycerol in bulk at 90 degC. The progress of reactions was followed with time and the extent of branching determined. Results obtained by CALB catalysis was compared with that by dibutyl tin oxide (DBTO) catalysis. DBTO catalysis results in crosslinked polyesters with low molecular weights. In contrast, CALB catalysis results in non-crosslinked functional polyesters with M_n up to 9 100. Changes in the stoichiometry of oleic diacid to glycerol was used to change the branch topology of products. The potential to further expand on the poly(glycerol-oleic diacid) platform to create a wide array of functional polyester materials will be discussed.

References

- Dodds, D. R.; Gross, R. A., Chemicals from biomass. *Science*, 318 (5854), 1250-1251 (2007);
Gross, R. A., Kalra, B; "Biodegradable Polymers for the Environment", *Science*, 297, 803-806 (2002).
Lu, W.; Ness, J.; Xie, W.; Zhang, X.; Minshull, J.; Gross, R.A. "Biosynthesis of monomers for plastics from renewable oils". *Journal of the American Chemical Society*, 132 (43): 15451-15455 (2010).
Yang, Y.; Lu, W.; Zhang, X.; Xie, W.; Cai, M.; Gross, R.A. "Two-step biocatalytic route to biobased functional polyesters from ω -carboxy fatty acids and diols". *Biomacromolecules* 11(1), 259-68 (2010).
Cai J.L., Hsiao B.S., Gross R.A.; "Polypentadecalactone prepared by lipase catalysis: crystallization kinetics and morphology" *Polymer International* 58(8): 944-953 (2009).

Novel Biobased Plastics, Rubbers, Composites, and Coatings from Agricultural Oils and By-products

Richard Larock, Iowa State University, United States
larock@iastate.edu

A remarkable range of exciting new rubber, adhesive, elastomeric and plastic materials can be made by the cationic, thermal and free radical copolymerization of various soybean oils with styrene, acrylonitrile, dicyclopentadiene and divinylbenzene. These materials possess excellent thermal and mechanical properties, plus outstanding damping and shape memory properties. Bioplastics from a range of other biological oils, including tung, corn, linseed and fish oils have also been prepared. In order to improve the polymer's performance, fillers, such as glass fiber, kenaf fiber, organic clay, wood flour, and agricultural co-products, such as soy hulls and distillers dried grains and solubles, have been used to reinforce these vegetable oil resins. The resulting biocomposites are very promising with significant improvement in the mechanical properties and thermal stability when compared with the resin alone. A number of novel new biobased waterborne polyurethane coatings and adhesives have also been prepared from agricultural oils.

Monomers and commodity chemicals from oleochemicals

David J Cole-Hamilton, Ruben Duque, Ronan le Goff, Marc Furst, Juma Mmongoyo, University of St. Andrews, U. K., and Quintino Mgani, University of Dar-es-Salaam, United Republic of Tanzania
djc@st-andrews.ac.uk

The synthesis of a series of alpha-omega disubstituted diesters of variable chain length starting from methyl oleate will be described. Reactions include metathesis, tandem isomerisation-methoxycarbonylation, hydrogenation, and reductive amination. Attempts at sequential reactions will also be described.

Some of these reactions have been carried out using the new technique of supported ionic liquid phase catalysis with supercritical fluid flow [1]. Using this technique, reactions using homogeneous catalysis can be carried out in flow systems so that the product is collected directly from the system with minimal catalyst or solvent contamination.

Approaches to the synthesis of commodity chemicals, such as detergents and polymer additives from cardanol and anachardic acid, which are available as waste products from cashew nut shell liquid, will be described.

[1] U. Hintermair, Z. Gong, A. Serbanovic, M. J. Muldoon, C. C. Santini and D. J. Cole-Hamilton, Dalton Trans, 2010, 39, 8501-10.

Linear Semicrystalline Polycondensates from Plant Oils

Florian Stempfle, Dorothee Quinzler, Ilona Heckler, Stefan Mecking
Universität Konstanz, Germany
florian.stempfle@uni-konstanz.de

Thermoplastic polymers are currently prepared almost exclusively from fossil feedstocks. In view of an ever increasing demand for fossil fuels and their limited range an increased utilization of renewable substrates is desirable on the long term. [1,2] Providing that the resulting polymers reflect the specific molecular structure of the (biomass) substrate, novel desirable property profiles may also result. Fatty acids from plant oils are attractive substrates. [3,4] They contain relatively long $-(CH_2)_n-$ chain segments, which can promote crystallinity and corresponding thermal properties, or a relatively high hydrophobicity. To fully utilize this potential, a complete linear incorporation of the entire hydrocarbon chain of the fatty acid is desirable. This can be brought about by isomerizing alkoxyacylation. [5,6] Hereby, from e.g. methyl oleate or ethyl erucate 1,19-dimethyl nonadecandioate or 1,23-diethyl tricosadioate, respectively, are formed in polycondensation grade purity ($> 99.5\%$). These compounds are the basis for other novel polycondensation monomers, and for novel polycondensates such as aliphatic polyesters with melting and crystallization points suitable for thermoplastic processing. [6]

[1] S. Mecking, *Angew. Chem., Int. Ed.* 2004, 43, 1078-1085.

[2] M. A. R. Meier, J. O. Metzger, U. S. Schubert, *Chem. Soc. Rev.* 2007, 36, 1788-1802.

[3] U. Biermann, W. Friedt, S. Lang, W. Lühs, G. Machmüller, J. O. Metzger, M. Rüsck-Klaas, H. J. Schäfer, and M. P. Schneider, *Angew. Chem Int. Ed.* 2000, 39, 2206-2224.

[4] D. Quinzler, S. Mecking, *Chem. Comm.* 2009, 5400-5402.

[5] C. Jimenez-Rodriguez, G. R. Eastham, D. J. Cole-Hamilton, *Inorg. Chim. Acta* 2005, 8, 878-881.

[6] D. Quinzler, S. Mecking, *Angew. Chem. Int. Ed.* 2010, 49, 4306-4308.

New ways to polymerize castor oil derived platform chemicals.

Oliver Kreye, Michael A. R. Meier, KIT, Karlsruhe, Germany
Oliver.kreye@kit.edu

The syntheses of new classes of polymers derived from the pyrolysis products of ricinoleic acid, the main fatty acid of castor oil, were investigated. The reaction sequence of aldol condensation and acyclic diene metathesis (ADMET) of 10-undecenal led to the formation of poly- α,β -unsaturated aldehydes.[1] The combination of isonitrile based multicomponent reactions (IMCRs),[2] e.g. the Passerini three component reaction or the Ugi four component reaction, with castor oil derived platform chemicals with olefin metathesis established an entry to highly diverse polymers with versatile post modification possibilities.[3] Both routes lead to interesting fatty acid derived functional group containing polymers and introduce new possibilities for polymer chemists.

[1] O. Kreye, T. Tóth, M. A. R. Meier, Eur. J. Lipid Sci. Technol. 2011, 113, 31-18.

[2] A. Dömling, Chem. Rev. 2006, 106, 17.

[3] O. Kreye, T. Tóth, M. A. R. Meier, J. Am. Chem. Soc. 2011, 133, 1790-1792.

Catalyst recycling in carbonylation reactions of fatty acids.

Andreas J Vorholt, Arno Behr, Lehrstuhl für Technische Chemie A (Chemische Prozessentwicklung), TU Dortmund, Dortmund, Germany
Andreas.Vorholt@bci.tu-dortmund.de

The replacement of fossil materials is a sophisticated challenge in chemical industry. Fatty compounds in particular are promising renewable raw materials with an annual output of 130 mio. T. In this development an effective chemical conversion of fatty compounds is gaining attention. Carbonylations of fatty compounds are very effective with homogeneous catalysts.¹ Recycling of these catalysts is essential for a sustainable chemical process.

In this lecture the recycling of various homogeneous catalysts for the hydroaminomethylation (HAM) and the hydroesterification (HE) will be presented. HAM is an auto-tandem reaction in which the hydroformylation with subsequent addition of an amine and hydrogenation of the resulting enamine. These reactions lead to different molecular classes of products with various amines. These reactions are catalysed by a rhodium catalyst. Moreover it will be presented a recycling approach utilizing thermomorphic solvent systems.

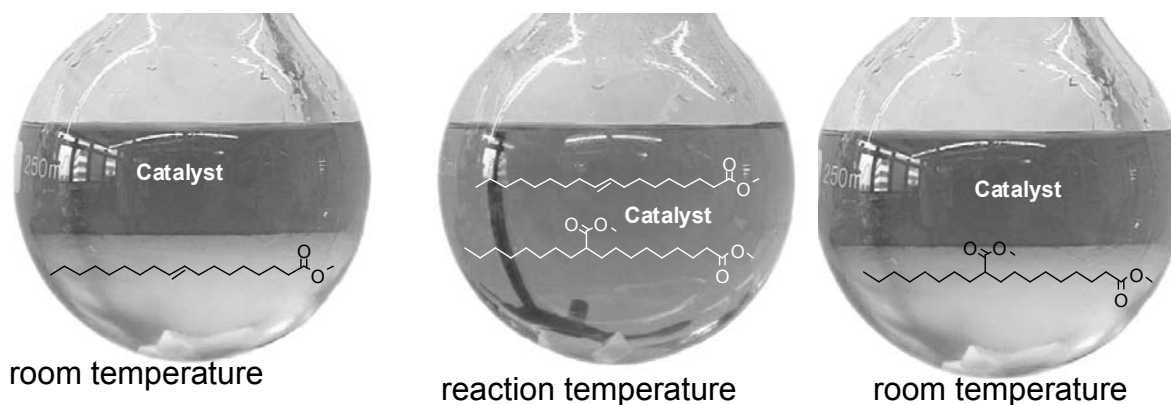

Figure 1: Hydroesterification of methyl oleate in a thermomorphic solvent system

Also the HE was introduced in a thermomorphic solvent system. HE is a promising way to introduce a second carboxylic group at the carbon chain.² This single step reaction adds carbon monoxide and an alcohol to the fatty acid. Variation of reaction parameters affords either linear or branched products. The leaching of metal into the catalyst phase can be influenced by different ligands and solvent ratios.

1. Behr, A.; Fiene, M.; Buss, C.; Eilbracht, P.; *European Journal of Lipid Science and Technology* **2000**, 102, (7), 467-471.
2. Jiminez-Rodriguez, C.; Eastham, G. R.; Cole-Hamilton, D. J.; *Inorganic Chemistry Communications* **2005**, 8, 878-881.

Green Approaches toward Plant-derived Monomers and Polymers via Thiol-Ene Click Chemistry.

Gerard Lligadas, Cristina Lluch, Rodolfo J González, Enrique del Río, Juan C Ronda, Marina Galià, Virginia Cádiz, University Rovira i Virgili, Tarragona, Spain
gerard.lligadas@urv.cat

The use of vegetable oils and fatty acids in polymer chemistry has become an important research area in constant growth. These renewable raw materials are considered as viable and economical substitutes to the scarce fossil feedstock and allow to synthesize polymeric materials with improved properties. Thus, it has been prepared a broad range of plant oil based monomers for the synthesis of some linear and multitude cross-linked structures.

The contribution of chemical industry to sustainable development not only involves the use of renewable raw materials but also the application of environmentally friendly processes. In this line, thiol-ene and thiol-yne click reactions have recently resurged in popularity due to their highly efficient and versatile chemistry. Their potential synthetic attributes are increasingly being exploited in macromolecular synthesis and functionalization.

We attempt to meet both principles, making use of fatty acids and oils as renewable feedstock and click chemistry as a valuable synthetic tool. This communication is focused in the discussion about the synthesis and polymerization of new plant-derived monomers and polymers via thiol-ene and thiol-yne click chemistry as well as the characterization of the resulting products.

Synthesis of biobased polyols by click chemistry from vegetable oils and their derivatives.

Sylvain Caillol, Myriam Desroches, Bernard Boutevin
Remi Auvergne, ENSCM, Montpellier, France
sylvain.caillol@enscm.fr

Polyurethanes are versatile plastics which occupy an important position in the world market of high performance synthetic polymers, with a global consumption around 8 million tons in 2000. They cover almost all the daily life aspects, such as building thermoinsulation, wood substitutes or coatings. Polyurethanes are traditionally prepared by reacting an oligomeric polyol and a diisocyanate. Whereas the isocyanate component is always derived from petrochemical feedstocks, the polyol component could come from bio-based resources. Vegetable oil-based polyols are synthesized from varied oils which, except castor oil, have to be chemically modified to meet the polyurethane production requirements. Transesterification and epoxydation are already industrially used for the production of polyols from oleochemicals.

The thiol-ene reaction represents another interesting toolbox for the functionalization of unsaturated vegetable oils. Indeed, this reaction of "click chemistry" allows photochemical or thermal initiation, undemanding synthesis conditions thanks to the insensitivity to oxygen inhibition, and leads to high yields with basic purification procedures.

Our team used reactive molecules bearing hydroxyl or amine functions to synthesize tailored modified vegetable oils. We investigated the effect of reaction conditions and showed that high conversion of double bonds into thioether is favored at high concentrations and high thiol/vegetable oil ratios. We also studied the impact of oil composition, reaction temperature and light intensity for thermal and ultraviolet initiated reactions respectively.

From polyfunctional bricks made from vegetable oil, we followed two pathways to synthesize biobased polymers: firstly, we used polyols in standard polyurethane synthesis to produce partially bio-based polyurethanes. Then, we synthesized biobased dicyclocarbonate and biobased oligomeric polyamines, that react together to form isocyanate-free polyurethanes. It is all the more interesting since cyclocarbonates could be synthesized by functionalization of glycerol, produced in large quantities by the transesterification of natural triglycerides as part of bio-diesel production. This method leads to totally biobased polyurethanes. In both cases, polyurethane materials synthesized were characterized by physicochemical analyses and thermal characterizations.

Branched macromolecules from plant oils: Towards greener strategies.

Lucas Montero de Espinosa, Michael A. R. Meier, KIT, Karlsruhe, Germany
Lucas.espinosa@kit.edu

Branched macromolecules, from monodisperse dendrimers to star-shaped and hyperbranched polymers, attract the attention of researchers from many different areas of science.[1] According to the required properties for each specific application, the structures of these macromolecules can be designed and, thanks to the fast advance of organic synthetic techniques, a synthetic route to the desired molecular architectures can very often be envisioned. However, most commonly, a convenient synthetic route involves the use of dangerous reagents and solvents, and does not consider the efficiency of the process. Although not always possible, the syntheses of branched macromolecules should be designed to adjust as closely as possible to the principles of Green Chemistry.[2] In this context, the use of plant oil derived building blocks, catalytic reactions such as olefin metathesis, and other efficient protocols such as thiol-ene additions will be discussed for the synthesis of renewable dendrimers and star polymers. As an example, we could recently show that the olefin cross-metathesis selectivity between terminal double bonds and acrylates can be used to design a renewable monomer that only polymerizes via head-to-tail additions. Thus, by taking advantage of this selectivity, we were able to prepare diblock and star-shaped polymers through this polycondensation approach.[3]

1. R. Hourani, A. Kakkar. *Macromol Rapid Comm* 2010, 31, 947-974; K. Inoue. *Prog Polym Sci* 2000, 25, 453-571.
2. P. T. Anastas, J. C. Warner. *Green Chemistry: Theory and Practice*, Oxford University Press: New York, 1998, p.30.
3. L. Montero de Espinosa, M. A. R. Meier. *Chem Commun* 2011, DOI: 10.1039/C0CC04161K.

Selectivity in Sorption and Hydrogenation of FAMES and Triglycerides on MFI Zeolites.

An Philippaerts,¹ Sabine Paulussen,¹ Stuart Turner,² Oleg I. Lebedev,² Gustaaf van Tendeloo,² Pierre Jacobs,¹ Bert Sels,¹

¹K.U.Leuven, Heverlee, Belgium; ² University of Antwerp, Antwerpen, Belgium
an.philippaerts@biw.kuleuven.be

Catalytic hydrogenation of vegetable oils is a well-known process in food industry to make the oil more resistant against air autoxidation and/or to obtain fats with a certain melting profile [1]. Unfortunately, hydrogenated edible oils have negative health impact, due to the cis/trans isomerization of the double bond, occurring in parallel with hydrogenation [2]. One aim of the present research is to investigate the fundamental basis for selective removal of trans-isomers from a hydrogenated oil sample via sorptive and size exclusion phenomena. It is known that zeolites act as molecular sieves, excluding the access of molecules with a diameter too large to enter the pores. The idea is to find a zeolite with a pore structure that is able to distinguish the linear trans chain from the bended cis chain. Next, the zeolites were loaded with Pt and tested in the selective hydrogenation of a mixture of methyl oleate (cis isomer) and methyl elaidate (trans isomer). Finally, the concepts found in the hydrogenation of FAMES were extrapolated to the level of triglycerides.

Different zeolite topologies were tested in order to find a pore system that is able to distinguish between the linear trans chain and the bended cis chain. ZSM-5 zeolite (MFI topology) appears the best choice: the quasi-linear trans isomer is sorbed more preferably. This preference was further investigated in relation to various compositional parameters, the Si/Al ratio of the zeolite matrix being the most important one. Loading the ZSM-5 zeolite with Pt clusters within the crystal matrix allows the selective hydrogenation of the trans-isomer, while leaving the cis-isomer almost unreacted. Obviously, the location of Pt is very critical. Only the Pt particles in the zeolite matrix will selectively hydrogenate the trans isomer [3]. Various synthesis procedures with varying compositions and heat pretreatment were investigated to locate Pt well dispersed within the zeolite matrix, as will be demonstrated with scanning and transmission electron microscopic images (with tomography). Besides the position of the Pt clusters, the zeolite particle size is another important parameter to selectively hydrogenate the trans-FAME isomer. Next, some of the Pt/ZSM-5 catalysts were tested in the hydrogenation of pure triglycerides and vegetable oils. The catalytic data show that some shape-selective Pt/ZSM-5 catalysts are capable of hydrogenating common soybean oils into stable (devoid of C18:3), essentially trans-free, fats with extraordinary plasticity, very useful for high-nutritive bakery shortenings.

[1] H.B.W. Patterson in "Hydrogenation of Fats and Oils: Theory and Practice, AOCS press, 1994.

[2] Mozaffarian, D., Katan, M., Ascherio, A., Stampfer, M., Willett, W. N. *Engl. J. Med.* 354, 1601 (2006).

[3] Philippaerts, A., Paulussen, S., Turner, O.I., Van Tendeloo, G., Poelman, H., Bulut, M., De Clippel, F., Smeets, P., Sels, B. Jacobs, P., *J. Catal.* (2010).

Electrochemical Conversion of Fatty Acids

Hans J. Schäfer, University of Münster, Germany
schafeh@uni-muenster.de

Electrochemical conversions combine an electron transfer with a chemical reaction, which allows conversions that are not available in non-electrochemical reactions. These are potential selectivity, redox-umpolung and substitution of a hydrogen atom for a nucleophile or the addition of two nucleophiles to a C-C double bond in one-pot reactions. Electrochemical conversions need mostly fewer steps, produce less waste, provide a cheaper reagent, require less auxiliaries and allow often an easier scale-up than non-electrochemical syntheses. In addition, they can be conducted at ambient temperature and pressure. All these qualities agree well with the rules of green chemistry.

The equipment is cheap, readily available and simple. One needs an electrolysis cell, electrodes, a solvent-supporting electrolyte and a power supply [1].

The electrochemical conversion starts at an electroactive site of the substrate. For fatty acids these are the carboxyl group, the C-C double bond [2,3,4] and the C-H bond. The carboxylate group is oxidized to a carboxylate radical that undergoes a fast decarboxylation to an alkyl radical. The radical can couple, add to a C-C double bond or can be further oxidized to a carbocation. The selectivity is controlled by current density, concentration, electrode material, supporting electrolyte and substituents at the α -carbon atom of the carboxylate. Examples are given for coupling and cross-coupling reactions to provide diesters, pheromones or C-glycosides [5].

Double bonds can be oxidized to cation radicals that react with nucleophiles to form allyl cations or lead to C-C double bond cleavage. These reactions are illustrated by anodic addition to conjugenic acid, allylic oxygenation of linoleic acid [6] and cleavage of the C-C double bond in oleic acid by indirect electrolysis with ruthenium(III)/ periodate as mediators.

For cathodic reduction of unsaturated fatty acids the C-C double bond has to be activated by an electron-withdrawing group, for example by conversion to an enone. This is achieved by an allylic oxidation of 10-undecenoic acid or by oxidation of ricinoleic acid and subsequent double bond conjugation. At the cathode these enones undergo a hydrodimerization to dimer fatty acids.

The (ω -1)- to (ω -5)-C-H bonds in dodecanoic acid, decanoic acid and octanoic acid are preferentially oxidized at the anode in dichloromethane/trifluoroacetic acid to trifluoroacetates [7].

References:

- [1] <http://www.aktuelle-wochenschau.de/2008/woche34/woche34.html>.
- [2] H. J. Schäfer, M. Harenbrock, E. Klocke, M. Plate, A. Weiper-Idelmann, *Pure Appl. Chem.* 79 (2007) 2047.
- [3] <http://www.aktuelle-wochenschau.de/2006/woche5b/woche5b.html>.
- [4] E. H. Pryde in *Fatty Acids* (E. H. Pryde, ed.) American Oil Chemists Society, 1979, 478.
- [5] A. Weiper-Idelmann, M. aus dem Kahmen, H. J. Schäfer, M. Gockeln, *Acta Chem. Scand.* 52 (1998) 672.
- [6] T. Breton, D. Liagre, E. M. Belgsir, *Tetrahedron Lett.* 46 (2005) 2487.
- [7] A. Hembrock, H. J. Schäfer, G. Zimmermann, *Angew. Chem.* 97 (1985) 1048.

Optimizing wax ester production in oil seed-crops.

Ivo Feußner, University of Göttingen, Germany

ifeussn@gwdg.de

The use of plant oilseed crops for the production of chemicals of industrial value has received increased attention in light of diminishing resources of fossil hydrocarbons. Of particular interest for technical applications are lubricants that are characterized by thermic stability and constant lubrication properties over a wide temperature range. A class of hydrocarbon-based chemicals with desirable lubrication properties are wax esters. Only few plant species, such as jojoba (*Simmondsia chinensis*), naturally produce wax esters, so in order to produce wax esters on a large scale in oilseed crops a suitable reaction sequence must be established by transgenic technology. Wax esters can be formed from plant-endogenous fatty acids by action of fatty acid reductase (FAR), which reduced fatty acids to their corresponding fatty alcohols, followed by wax synthase (WS), which condenses a fatty acid and a fatty alcohol to form the wax ester. For different industrial applications, wax esters of varying chain lengths are desirable and, thus, one task is to isolate FAR and WS enzymes with suitable catalytic specificities. Another task is to ensure proper cooperativity of FARs and WSs in the host organism in order to maximize catalytic efficiency. Here, the interplay of FARs with WS is systematically tested to optimize wax ester production. Enzymes from different biological sources have been identified and introduced in yeast (*Saccharomyces cerevisiae*) to establish wax ester production. Rational modification of enzymes has been attempted to optimize the interplay of FARs and WSs with the aim to provide a range of possible combinations tailored to the production of different species of wax esters.

This project is supported by the EC FP7 project "Industrial Crops producing added value Oils for Novel chemicals" (ICON).

Continuous Production of 1,3-Propanediol Using Waste Glycerol with *Clostridium Beijerinckii* NRRL B-593 Immobilized on Glass Beads and Glass Rushing Rings.

Nuri Azbar, Mine Gungormusler, Cagdas Gonen, Ege University, Izmir, Turkey
nuriazbar@gmail.com

Among the economically viable and ecologically acceptable solutions for the safe disposal of this waste glycerol came from biodiesel production, biotechnological conversion of glycerol into a very high-value added bioplastic raw material, namely 1,3 propanediol (1,3 PDO) seems to be very promising. Biotechnological routes consist of fermentation processes which use microbiological methods by microorganisms. This process is easy and environmentally friendly since it doesn't produce any toxic wastes. The results indicated that by-product glycerol is amenable for 1,3 PDO production as well as pure one. The immobilization process has important advantages. Namely, with less reactor volumes in shorter fermentation times it is possible to obtain higher yields, growth and production rates. In this paper, the immobilization capacity of *C. beijerinckii* B-593 on glass beads and glass rushing rings with industrial glycerol was studied. Maximum volumetric productivity of the system reached 7,2 g/L.h 1,3 PDO corresponding to a product concentration of 14,4 g/L with continuously immobilized process at 2 hours hydraulic retention time (HRT) on glass rushing rings. It was demonstrated that continuous production of 1,3 PDO from waste glycerol immobilized is feasible and immobilized bioreactor systems outcompeted the conventional suspended culture bioreactors in terms of both productivity and operational stability.

Process Development and Environmental Assessment of Chemoenzymatic One-Pot Processes.

Harald Gröger, University of Erlangen, Germany
Harald.Groeger@chemie.uni-erlangen.de

Multi-step one-pot processes represent an attractive synthetic concept for the improvement of overall process efficiency by decreasing the required number of work up and purification steps. By avoiding such time-, capacity- and solvent-intensive process steps, multi-step one-pot syntheses contribute to a significantly improved process economy as well as to more sustainable synthetic routes. A key criterion for multi-step one-pot processes is the compatibility of the individual reaction steps with each other. Accordingly, most of today's known multi-step one-pot processes are based on either chemocatalytic multi-step reactions or "pure" biotechnological processes such as, e.g., fermentation. In contrast, successful combinations of chemo- and biocatalytic reactions, in particular in aqueous media, are much less widely known.

In this contribution strategies for the combination of chemo- and biocatalysts for the development of multi-step one-pot processes, e.g., in aqueous media, are presented. Since palladium-catalyzed cross-coupling reactions are of particular importance in the field of metal catalysis, as enzymatic reductions are in the field of biocatalysis, we were interested in the investigation of the compatibility of these types of reactions with each other in water. As an example for such a one-pot process the synthesis of chiral biaryl-containing alcohols via Suzuki-cross-coupling reaction and subsequent asymmetric enzymatic reduction is discussed.[1,2] In addition, the combination of a metal-catalyzed cross-metathesis reaction with a biotransformation has been accomplished. A combination of an organo- and biocatalytic reaction sequence has been demonstrated for the transformation of aromatic aldehydes into 1,3-diols with two stereogenic centers.[3]

A further chemoenzymatic one-pot process, which proceeds under neat conditions, led to an enantioselective synthesis of ethyl (S)-3-amino butanoate.[4,5] The reaction steps comprise an initial aza-Michael addition and a subsequent enzymatic resolution via aminolysis. Subsequent derivatization gave the corresponding beta-amino acid with an excellent enantiomeric excess of 99% ee. An environmental assessment for the whole reaction sequence, which is based on the use of readily available raw materials and does not require a column chromatography with organic solvent, has also been done with modern software programmes EATOS and Sabento/Umberto. An E-factor of 41 has been determined for the whole reaction sequence.[5]

[1] E. Burda, W. Hummel, H. Gröger, *Angew. Chem.* 2008, 120, 9693-9696; *Angew. Chem. Int. Ed.* 2008, 47, 9551-9554

[2] E. Burda, W. Bauer, W. Hummel, H. Gröger, *ChemCatChem* 2010, 2, 67-72.

[3] K. Baer, M. Krauß, E. Burda, W. Hummel, A. Berkessel, H. Gröger, *Angew. Chem.* 2009, 121, 9519-9522; *Angew. Chem. Int. Ed.* 2009, 48, 9355-9358.

[4] M. Weiß, H. Gröger, *Synlett* 2009, 1251-1254.

[5] M. Weiß, T. Brinkmann, H. Gröger, *Green Chem.* 2010, 12, 1580-1588.

Chemical Modifications of *Sterculia foetida* Oil to Highly Branched Products.

Louis Daniel,¹ H. H. van de Bovenkamp,¹ Teddy Buntara,¹ Siti Maemunah,¹ Gerard Kraai,¹ I. G.B.N. Makertihartha,² Robert Manurung,² Hero J. Heeres,¹ University of Groningen, Netherlands; ² Bandung Institute of Technology, Indonesia
L.Daniel@rug.nl

Sterculia foetida is a tropical tree that is widespread in Indonesia (East Java, Bali and eastern Indonesia). 50-70 %-wt of the fatty acid chains in *Sterculia* oil contain cyclopropene units, one of the most strained structures in organic molecules [1]. This unit is an excellent starting point for further modification chemistry to prepare novel derivatives with applications in the field of cold-flow improvers and/or bioplasticisers for polymers like PVC. We here report an experimental study to introduce branches in the fatty acid chain by both catalytic and stoichiometric chemistry. Examples are Diels-Alder reactions, olefin metathesis, oxidations, (*trans*)-esterification, as well as rearrangement reactions. NMR and various derivatisation techniques combined with GC-MS were used to characterise the products. Reactions of *Sterculia* methyl esters with two representative dienes (furan and cyclopentadiene [2], Scheme 1a) were performed and 100% conversion and selectivity were obtained for cyclopentadiene using water as the solvent at 40 °C.

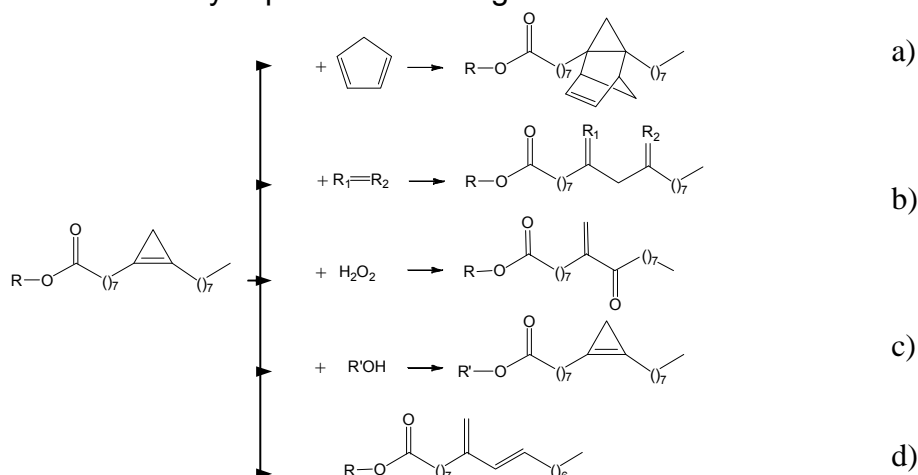

Scheme 1 Chemical modifications of *Sterculia foetida* oil (R= alkyl or remaining triglyceride structure, R_1, R_2 = substituents of the olefin, R' =branched alcohol)

Metathesis reactions (Scheme 1b) were performed at 40-55 °C with 2,3-dimethyl-2-butene, 1-octene, and methyl stercolate (self-metathesis) using Grubbs' catalyst 2nd generation. 100% cyclopropene conversion was obtained with 2,3-dimethyl-2-butene. Oxidation reactions (Scheme 1c) gave 100% conversion of the cyclopropene units at room temperature and resulted in the formation of an α, β -unsaturated ketone (enone) as major product [3] and mono- and di-acids as minor products, depending on the reaction conditions. *Trans*-esterification and rearrangement reactions gave products as depicted in Scheme 1d and 1e, respectively. Details on the catalytic reactions as well as relevant product properties will be provided in this contribution.

- [1] Greenberg, A., Harris, J., *J. Chem. Educ.* 59 (1982) 539.
 [2] Binger, P., Wedemann, P., Brinker, U. H., *Org. Synth.* 10 (2004) 231.
 [3] M. Nakatani, Y. Matsuoka, Y. Uchio, T. Hase. *Chem. Lett.* (1990) 669.

Latent Heat Characteristics of Oleochemical Carbonates and their Eutectic Mixtures as Potential Phase Change Materials

Jim Kenar, USDA-ARS-NCAUR, Peoria, IL, USA
jim.kenar@ars.usda.gov

Phase change materials (PCM) absorb and release latent heat upon changing phases from solid to liquid (melting) or from liquid to solid (solidifying) and can be used in thermal energy storage applications to recover waste heat, store thermal energy, and improve energy conservation and efficiency. Oleochemical carbonates, readily prepared from renewably available C10-C18 fatty alcohols, were examined as potential PCM. The latent heats of melting and freezing for a series of oleochemical carbonates and their mixtures were evaluated by differential scanning calorimetry (DSC) and thermal gravimetric analysis (TGA) to develop a fundamental understanding of the solid-liquid transitions of these materials for utilization in thermal energy storage applications. It was found that pure oleochemical carbonates possess melting and solidifying temperatures ranging from 0-52 oC and have relatively high heats of fusion ranging from 144-223 J/g. Additionally, it was found the oleochemical carbonates could be mixed together in various proportions to adjust melting/solidification temperature ranges. This presentation will discuss the various aspects of biobased oleochemical carbonate synthesis, their use as phase change materials, and how they compare to fatty acids and esters used as PCM.

Auto-organization and polymorphism properties of pure short and medium chain monoglycerides and glycerol carbonate esters.

Romain Valentin, Zéphirin Mouloungui, INRA, France
romain.valentin@ensiacet.fr

Pure alpha-monoglycerides (MGs) , and glycerol carbonate esters (GCEs) are two families of lipochemical molecules composed of a polar building block, glycerol for MGs, glycerol carbonate for GCEs, and a fatty acid lipophilic part. These molecules glycerol derived take part to the valuation of the produced glycerine in the process of lipochemical synthesis such as that of the biodiesel.

From a chemical point of view, MGs include 2 free oxygen in the hydroxyl functions and one ester function between the fatty acid and the glycerol parts, GCEs contain 2 blocked oxygen in the cyclic carbonate backbone and 3 esters functions, 2 endocyclic in the five-membered cyclic carbonate function , 1 exocyclic between the fatty acid and glycerol carbonate parts. At the physico-chemical level, MGs and GCEs³ are bifunctional molecules with amphiphilic structures: a common hydrophobic chain to the both families and a polar head, glycerol for MGs and glycerol carbonate for GCEs. The physico-chemical properties of these both families of oleochemical biomolecules, containing chain lengths comprised between 7 and 18 atoms of carbon, are determined and compared. Differential scanning calorimetry and optical polarized light microscopy allow us to highlight the self-assembling properties of the glycerol carbonate esters alone and in presence of water. We demonstrated by thermal analysis the polymorphic behaviour of GCEs, and the correlation between their melting points versus the chain lengths. The solvo-surfactant character of MGs and overall GCEs were discussed through the measurements of critical micellar concentration (CMC) or critical aggregation concentration (CAC). These surface active glycerol/glycerol carbonate esters were classified following their hydrophilic/hydrophobic character correlated to their chain length ($\text{LogPoctanol/water} = f(\text{atom carbon number})$). To conclude, polymorphic GCEs present a different sensitivity than MGs to the cooling rate (controlled phase behavior). Carbonation decreases melting points : 2 OH functions of MGs involved in intra and intermolecular hydrogen bonds. Carbonation decreases the hydrophilic character of the polar head of surface-active GCEs.

What is Meant by 'Bio'? The Use of Renewable Raw materials for Lubricants Business.

Rolf Luther, Fuchs Europe Schmierstoffe GmbH, Mannheim, Germany
rolf.luther@fuchs-europe.de

Environmentally compatible lubricants, often simply named bio-lubricants, are principally well known since long years. Nearly 20 years the German Ecolabel "Blauer Engel" was introduced for different types of lubricants, e.g. chain saw oils, 2-stroke engine oils, concrete release agents, total loss greases and hydraulic fluids; since 10 years this last one product group is technically described by ISO 15380 "Environmentally acceptable Hydraulic Fluids". Moreover, since 5 years a European Ecolabel for Lubricants is available, as well for lubricating greases and hydraulic fluids. But looking on the different labels, "standards" and declarations: What is meant by "bio"? The "bio-" prefix is often considered as a synonym of good for the environment, or in another situation, good for health. The prefix "bio", when associated with lubricants, can be perceived as an indication of biodegradability by the consumers. In other words, a "bio-lubricant" is expected to biodegrade (to break down in the environment). On the other hand, the term bio-lubricant also strongly conveys the idea of natural origin, as "bio" is taken as an indication of the biological world. An analogy is the term "biofuel" – universally taken as implying a fuel derived from renewable resources. Obviously, different types of so-called "bio-lubricants" are actually present in the marketplace. This is a cause of concern as it can be the source of misleading information and confusion for the final consumers.

However, since few years the questions with regard to climate change and use of renewable raw materials in industrial products came up more and more: Within the "Lead Market Initiative for Europe" (LMI) the "bio-based products" have been identified for the initial stage of the initiative, including bio-polymers and bio-lubricants.

As a consequence of the LMI, the European Committee for Standardisation (CEN) was assigned to generate a Technical Report 'Bio-Lubricants', which should define a general understanding of bio-lubricants. In addition to existing eco-labels the reputation of this approach should not be based on certification systems, but on the product itself: Every claim with regard to biodegradability, toxicity and bio-based content should be measurable in the final product by the customer. Finally, the minimum requirements for "bio-lubricants" according to CEN are suggested as follows:

-- Renewability: The content of renewable raw material amounts at least to 25 % according to ASTM D 6866 (radiocarbon analysis).

-- Biodegradability: according to OECD 301 B, C, D or F: ≥ 60 % for oils; ≥ 50 % for lubricating greases

-- Toxicity: Not to be labelled as "Dangerous to the environment" (Symbol N) according to CLP Directive 1272/2008/EC (Classification, Labelling, and Packaging). This may be proven for the fully formulated product by testing according to OECD test no. 201/202/203: EC50/LC50/IC50 > 100mg/l.

-- Performance: "Fit for purpose" or "Fit for use". The lubricant manufacturer and the customer using the product both need to ensure that the recommended lubricant is suitable for a specific application; in other words, the appropriate specifications have to be fulfilled.

-- Any lubricant according to the present criteria of the EU Ecolabel for Lubricants (2005/360/EC) is a "Bio-lubricant" per definition.

Often bio-lubricants are perceived as low performance lubricants. It should be recognized, that modern high performance bio-lubricants can meet and even exceed the performance of conventional lubricants in the market.

However, it has to be stated that the market share of bio-lubricants has not reached the forecasts. Don't our customers ask for bio-lubricants? Far from it, the interest is given, but the main reason for moderate purchase of these products lies in the cost situation – up to now, bio-lubes mostly are more expensive than conventional ones. The question has to be discussed how chemical research and de-velopment can help to change this situation.

New heterogeneous catalysts for the production of biodegradable lubricants.

Federica Zaccheria,¹ Nicola Scotti,² Simona Brini,³ Gabriele Ricchiardi,³ Nicoletta Ravasio,¹ Rinaldo Psaro,¹ ¹ CNR ISTM, Italy; ² CNR ISTM; ³ NisLabVCO, Italy
f.zaccheria@istm.cnr.it

The annual global production of lubricants and related functional fluids like hydraulic fluids, transformer oils, heat transfer fluids and metal working coolants is approximately 38 Mtes and the demand is supposed to reach 40.5 Mtes in 2012 (Freedonia Group forecast). By comparison annual global production of chemicals in total is estimated at 400 Mtes. Manufacture and eventual disposal of this very large volume of material obviously represents an environmental burden.

In some applications the requirements for biodegradable hydraulic fluids and lubricants can be met by the use of vegetable oils. Natural oils have some good lubricant properties, including high viscosity indices and high flash points. However they have a limited viscosity range because of their limited range of structures and they suffer from poor low temperature fluidity and very poor thermal and oxidative stability, which leads to rapid degradation, thickening and deposit formation in use.

Oxidative stability depends on the amount of polyunsaturated fatty acids in the oil. Main unsaturated fatty acids in vegetable oils such as rapeseed, soja and sunflower oil are linolenic (all *cis*-9,12,15-octadecatrienoic, C18:3) linoleic (all *cis* -9,12-octadecadienoic, C18:2) and oleic (*cis*-9-octadecenoic acid, C18:1). Their relative rate of oxidation is respectively 100:40:1, therefore partial hydrogenation of these oils should result in strong stabilization towards oxygen. However to preserve fluidity it is mandatory not to increase the melting point, that depends on both the saturated compound C18:0 (stearic acid) content and the extent of *cis*-*trans* and positional isomerization. Up to now catalysts able to improve the oxidative stability while keeping good cold properties through a selective hydrogenation process are rare.

We already reported that a series of pre-reduced 8% Cu/SiO₂ catalysts can be conveniently used for the stabilization of vegetable oils and their methylesters. In the case of rapeseed oil methylesters the trienic C18:3 component can be eliminated and the dienic C18:2 one lowered from 22 to 3-5% without rising the stearic C18:0 content and limiting the *cis*-*trans* isomerization process. These oils with a C18:1 content up to 88% (in the case of methylesters) show remarkable oxidative stability and keep fluid down to -12, -15°C [1,2]. Pour point, AOM test, viscosity at 40° and 100°C and viscosity index of the oil obtained through hydrogenation of rapeseed oil (glycerol ester) were very good for lubricating end uses. In particular, Viscosity and viscosity index keep unchanged also after the accelerated oxidation test (AOM). Thermal stability depends on the presence of H atoms located in the beta position of ester groups, thus making the glycerol esters susceptible to elimination reaction and subsequent degradation of the native molecule. That is why so called hindered esters, that is esters of fatty acids with alcohols without H atoms in beta position, are preferred for lubricants that have to withstand high temperature and pressures. Methodologies actually in use for the production of biobased esters from the corresponding fatty acids (mainly) rely on the use of homogeneous acidic catalysts such as sulfuric, *p*-toluene-sulfonic and hydrochloric acid. All of them show corrosion

problems and need to be neutralized after the reaction, thus producing significant amounts of inorganic salts containing effluents to be disposed of.

We recently reported that silica zirconia and silica alumina mixed oxides can be effectively used for the esterification of highly acidic oils with methanol [3]. The catalysts are heterogeneous in nature, are stable to leaching and are not poisoned by the water formed during reaction, therefore giving high yield in esters without producing any inorganic waste. In the present communication we wish to report results obtained on the synthesis of new lubricants with improved performances by combining the highly selective hydrogenation process and the heterogeneous catalyzed esterification through the use of Cu catalysts supported on acidic materials. This would allow one to produce lubricants starting from highly unsaturated non food oils like flaxseed and hempseed oil through a low impact process that does not produce inorganic wastes. These lubricants will be not only more environmentally friendly due to their high biodegradability, but also very much safer to use due their high flash point.

We will report results obtained in the direct esterification of Palm Oil Fatty Acids Distillates, a by product of Palm Oil refining containing 95% Free Fatty Acids, with Tri Methylol Propane (TMP) over heterogeneous silica zirconia and on the simultaneous hydrogenation and esterification with methanol of Tall Oil, a byproduct of the pulp & paper industry, formed by a mixture of highly unsaturated free fatty acids over a catalyst prepared by supporting Cu over the same silica zirconia material.

E.g. a 2 hours treatment at 180°C under 6 bar of H₂ of Tall oil over Cu/SiO₂-ZrO₂ gave a reduction in the content of FFA from 98 to 15% and a reduction of Iodine Value IV (a measurement of the unsaturation level) from 160 to 140, showing that both the esterification and the hydrogenation reaction can take place in a one pot reaction over a single catalyst.

Table 1- Simultaneous esterification and hydrogenation of Tall Oil carried by using Cu/SiO₂-ZrO₂ as heterogeneous catalyst in the presence of methanol

Catalyst	t (h)	FFA (%)	IV
Cu/SiO ₂ -ZrO ₂	0	98	160
	2	15	140

- 1) N.Ravasio, F.Zaccheria et al. Applied Catalysis A: General, 233 (2002) p.1
- 2) F. Zaccheria, R. Psaro, N. Ravasio, Green Chemistry, 11 (2009) 462-465).
- 3) F. Zaccheria, S. Brini, R. Psaro, N. Scotti, N. Ravasio, ChemSusChem, 2 (2009) 535-537

Novel Lipid-Modified Carbohydrates – Potential Oil Soluble Antioxidants and Gelators

Sukhendu Nandi, Hans-Josef Altenbach, Manfred P. Schneider, Bernd Jakob, Karsten Lange, Rachid Ihizane, Bergische Universität Wuppertal, Germany
s.nandi@uni-wuppertal.de

Agricultural crops provide a considerable reservoir of useful and low cost raw materials such as fats, oils and carbohydrates. By selective combination of their molecular constituents, numerous novel materials with interesting properties can be prepared. All of them, due to their molecular constitution, being potentially highly biodegradable and non-toxic, have attracted much interest in cosmetic and nutrition industry.

We have found that hydroxycarboxylic acids like malic and tartaric acid can be converted in one step and quantitatively into the corresponding O-acylated anhydrides by reaction with fatty acid chlorides [1] without any solvents. These materials are excellent and highly reactive electrophiles, which easily and quantitatively undergo ring opening reactions with nucleophiles from various renewable resources such as L-ascorbic acid (vitamin C), sugar alcohols and monosaccharides (e.g. D-glucose, D-glucosamine).

In order to correlate structure-property relationships of those materials we have synthesized small libraries of amphiphiles with different alkyl chains. In addition to surface and emulsifying properties, several of the thus resulting molecules show additional benefits like gelation properties in a wide range of solvents. Especially lipid modification of L-ascorbic acid (vitamin C) leads to oil soluble derivatives that are potentially useful as antioxidants for the stabilization of native plant oils.

The lecture will describe the syntheses of these novel combination products and discuss their properties in terms of potential, practical applications.

[1] Lange. K.; Schneider. M.P. German Patent DE 102006014732 A1, 2006

Biodegradable Polymers for Packaging Applications.

Andreas Künkel, BASF, Ludwigshafen, Germany
andreas.kuenkel@basf.com

Biodegradable polymers are sustainable alternatives to standard plastics in applications where the functional property of biodegradability is an advantage. Ecoflex® is the brand name of completely biodegradable aliphatic-aromatic polyesters produced by BASF. Ecoflex® combines very good mechanical properties with complete biodegradability and is in certain applications a drop-in substitute for standard plastics like polyethylene or polystyrene. By the use of renewable raw materials either in the production of Ecoflex® itself and/or by blending with bio-based polymers like starch or poly(lactic acid) biodegradable plastics with new and interesting properties profiles are obtained. Compounds of Ecoflex® and PLA are commercialized by BASF under the brand name Ecovio®. The application range of Ecoflex® and Ecovio® is very broad: from film applications like organic waste bags, shopping bags or agricultural mulch films to knitted nets, shrink films, coated paper board and stiff foamed packaging.

Fatty Acid Methyl Esters as Reactive Diluents in Thermoset Coatings.

Mats K. G. Johansson, KHT, Stockholm, Sweden
matskg@kth.se

Vegetable oils and derivatives thereof has a long tradition in the field of organic coatings. Oil based resins are dried via chemical crosslinking reactions that either are oxidation reactions using atmospheric oxygen (alkyds or linseed oil coatings) or other chemical reactions such as cationic polymerization (epoxidized oils) and amino crosslinking reactions (alkyd / melamines).

Systems based on polyunsaturated fatty acids normally dry via an oxidative crosslinking route catalysed by various driers such as transition metals salts. These systems range from linseed oil paints to more modern alkyd based systems and hybrid systems such as alkyd/acrylates. The coating applications range from impregnating oils on wood where the oils act as a primer that hydrophobize the wood surface to alkyd top coats for both wood and metal substrates. The widespread use of vegetable oil monomers in a large variety of coatings indicate that these monomers have intrinsic properties suitable for protective coatings. The use of vegetable oil based monomers has however not increased too much during the 1900's due to competition from synthetic monomers such as acrylates and other fossil based raw materials. Increased environmental concerns in combination with increased oil prices and development of new chemistries as well as modern crops development has however spurred an increased interest both academically as well as industrially for monomers based on renewable resources.

One large volume industrial coating process is the production of pre-coated sheet metals which are produced in a continuous process to form coated steel coils (coil coating systems). The pre-coated sheet metal is then cut and formed in its coated state to form numerous different products ranging from drain pipes to light casings. The conventional coating process employs solventborne coatings with a solid content of typically 50%. Although the solvent is recovered as energy within the process there is a strive to reduce the amount of solvent due to economical and environmental concerns. The systems presently used are normally traditional resins such as PVC-plastisols or melamine /polyesters based on fossil resources. An introduction of renewable materials would thus also be positive from an environmental point of view.

The present study describe how fatty acid methyl esters (FAME's) can be introduced as reactive diluents in traditional thermally cured coil coatings giving several positive effects.

A blend of different FAME's is normally obtained from specific crops oils why it is difficult to perform polymerization reaction on all monomers if the functionalities in the alkyl chain are to be employed (e.g alken, epoxy, hydroxyl groups). One functional group is however common for all FAME's, the acyl group of the ester. This functional group is for example used in resin synthesis when fatty acids are incorporated into an alkyd, resin but there is little reported on use of this functional group during a curing process. The concept of the present work is to replace a significant fraction of conventional solvents with a FAME in a thermally cured solventborne melamine / polyester system. The process is a continuous thermal curing process where the coating is cured in a convection oven at 300 °C for 30 seconds to give a peak metal temperature of approximately 230 °C. The FAME will act as a solvent before curing and then be chemically incorporated into the final cured coating via a transesterification with the polyester. FAME's are low viscous, has good solvent properties, and shown to allow a significant reduction in solvent content of the paint. The results also show that a significant fraction of FAME's can be transesterified onto a hydroxyfunctional polyester in parallel to melamine crosslinking of the polyester. A fraction of the FAME is evaporated and the remainder reacted into the final film as determined by C14-dating. Extraction studies of the cured film confirm that no free FAME is left in the final film. The overall results show that a reduction in solvent content, an introduction of renewable monomers, and a technical performance of the system at least as well as traditional coatings can be obtained when using FAME as a reactive diluent in a thermally cured melamine / polyester coating.

References

- Z. W. Wicks Jr, F. N. Jones, s. P. Pappas, D. A. Wicks "Organic Coatings: Science and Technology, John Wiley & Sons Inc., Hoboken, NJ, USA (2007)
- Z. O. Oyman, "Towards environmentally friendly catalysts for alkyd coatings" PhD-thesis, TUE, Eindhoven, the Netherlands, (2005)
- J. T. P. Derksen, F. P. Cuperus, P. Kolster Prog. Org. Coat., 27, 45-53 (1996)
<http://www.prepaintedmetal.eu/>
- K. Johansson, M. Johansson Prog. Org. Coat., 55, 382-387 (2006)
- K. Johansson, M, Johansson Prog. Org. Coat., 59, 146-151 (2007)
- K. Johansson, M, Johansson Prog. Org. Coat., 63, 155-159 (2008)

Biohybrid Silver Nanocomposites as Antimicrobial Surface Coating Materials.

Deewan Akram,^{1,2} Eram Sharmin,¹ Sharif Ahmad,¹

¹Materials Research Lab., Dept. of Chemistry, Jamia Millia Islamia, New Delhi, India;

²Dept. of Chemistry, Faculty of Science, Jazan University, Jazan, KSA
deewanakram@gmail.com

Polymer/metal nanocomposites have attracted great attention because of the combination of both the properties of the inorganic nanoparticles, such as optical, antimicrobial, electrical, or mechanical properties, and those of the polymer, such as processability, solubility and chemical resistance¹⁻³. However, the dispersion of nanoparticles into a polymer matrix has been a bottleneck for nanocomposite fabrication. Silver nanoparticles have attracted particular interest due to their favourable optical properties, displaying surface plasmon resonance, non-linear optical limitation, electrical properties, ability to modify the refractive index of host materials, catalysis, conductive inks, thick film pastes, adhesives for various electronic components, and superior to other metals in antibacterial effects¹⁻⁵.

In this study, we have attempted to develop organic-inorganic hybrid polyurethane silver nanocomposite (Ag/LPOSiPU). Synthesis carried out in three steps- (i) synthesis of organic-inorganic hybrids (LPOSi) from linseed polyol (LPO-Obtained from epoxidation and hydroxylation of Linseed oil) as organic and tetraethoxyorthosilane (TEOS) as inorganic precursors, respectively through sol-gel process, (ii) preparation of silver nanoparticles in organic-inorganic hybrids (LPOSi) via reduction of silver salt (AgNO₃) by employing N,N-dimethylformamide (DMF) as reducing agent at room temperature to obtain Ag/LPOSi, and (iii) Ag/LPOSi further treated with toluene 2,4 di-isocyanate to form their polyurethane (Ag/LPOSiPU). Ag/LPOSiPU was applied on mild steel strips to evaluate their coating performance. The structure, morphology, and thermal stability, of the resulting Ag/LPOSiPU have been investigated by FTIR, X-ray diffraction, transmission electron microscopy (TEM), scanning electron microscopy (SEM), UV-visible, and thermogravimetric analysis (TGA). These studies substantiate the formation of well-dispersed silver nanoparticles within the LPOSiPU matrix. The physico-mechanical and corrosion/chemical resistance (by weight loss and electrochemical method in various corrosive media such as 3.5%HCl, 3.5%NaOH, Xylene, Salt mist test) performance were conducted to evaluate the coating properties of synthesized Ag/LPOSiPU. The antimicrobial efficacy of Ag/LPOSiPU was also premeditated and highly antibacterial activity against Gram negative bacteria (*Escherichia coli*) and Gram positive bacteria (*Staphylococcus aureus*) were observed. These studies revealed the impeccable behavior of the synthesized polymeric materials, which serve as novel and promising candidates for use as nanostructured antimicrobial corrosion protective coating materials and can be safely employed up to 240°C.

References

- 1 Akram, D.; Ahmad.; S.; Sharmin, E.; Ahmad, S, *Macromol.Chem.Phys.*2010, 211, 412
- 2 Jiang, H. C.; Chen, W. M.; Chen, C. Y.; Xiong, S. X.; Yu, A.B, *Nanoscale. Res.Lett.* 2010.
- 3 Kumar, A.; Vemula, P. K.; Ajayan, P.M.; John, G, *Nature Materials*, 2008, 7, 236.
- 4 Konwar, U.; Karak, N.; Mandal. M, *Prog. Org. Coat.* 2010, 68, 265.
- 5 Singh, N.; Khanna, P. K., *Material chemistry and physics.* 2007, 104, 367.

Production of polyglycerol from renewable sources.

Marc A. Dubé, University of Ottawa - Dept. of Chem. and Biol. Engineering, Canada
Marc.Dube@uOttawa.ca

In recent years, the interest in the use of bio-based polymers has grown tremendously. These types of polymers have a lower environmental burden and are an ideal alternative to conventional polymers made from petroleum, which is a limited natural resource. Due to a significant glut in the glycerol market because of increasing biodiesel production, interest in finding economic ways to utilize the emerging surplus has grown. Currently, new opportunities for the conversion of glycerol into value-added chemicals have emerged due to the unique structure and properties of glycerol, its biocompatibility and biodegradability. One approach to use this glycerol surplus is polymerization. Until now, only oligomers have been synthesized directly from glycerol. On the other hand, high molecular weight polyglycerols, such as hyperbranched polyglycerol, have been produced from toxic monomers, which are environmentally hazardous (e.g., glycidol). In this study, the step-growth polymerization of polyglycerol to relatively high molecular weight from glycerol feedstock was investigated. A focus of our investigation was the use of different catalysts to improve the polymer properties. The biocompatibility and functionality of the polymer makes polyglycerol an interesting option for pharmaceutical and medical applications. In particular, the structural similarity of polyglycerol to the well-studied polyethyleneglycol (PEG) makes it a compelling candidate for PEG replacement in many applications.

Glycerol as solvent: a new tool for the design of environmentally friendly catalytic processes.

F. Jerome, M. Delample, J. Barrault; CNRS-LACCO, Poitiers, France, and J.P. Douliez, BIA-INRA, Nantes, France
francois.jerome@univ-poitiers.fr

Immobilization of homogeneous catalysts in a liquid phase has become a very important issue in the field of catalysis and is a smart strategy when the direct grafting/deposition over a solid support is too complex to be achieved. Idea is here to immobilize a homogeneous catalyst in one liquid phase while the reaction products are selectively extracted (ideally continuously) with a co-solvent. In this context, ionic liquids (ILs) are probably the most investigated solvents. Indeed, their high polarity along with their low solubility with common organic volatile solvents makes of ILs some attractive solvents for the immobilization of homogeneous catalysts. However, the price and hazardous toxicity of ILs represent the main drawbacks to their large scale utilization. Inspired by our recent works in the field of the selective conversion of glycerol to higher value added chemicals, we have shown that glycerol can be used not only as a reactant but also as a very convenient solvent for the immobilization of catalysts.^[1] As compared to ILs, main advantages of glycerol stem from its biodegradability, its non toxicity, its renewability and its very attractive price (0.5€/kg).

Like in the case of water, the design of catalytic processes in glycerol requires to overcome important mass transfer problem stemming from the high hydrophilicity of glycerol. In this communication, we will show that the low solubility of organic substrates and the intrinsic reactivity of glycerol can be circumvented using surfactant-combined-catalysts derived from sugars. Reversely to what was observed in water, emulsions created in glycerol are much less stable. Therefore, at the end of the reaction, the products can be easily recovered by simple decantation thus allowing the successful recycling of the catalyst. When the products of the reaction are now in a solid state, we will show that the products of the reaction can be cleanly and selectively extracted from the glycerol/catalyst phase with supercritical carbon dioxide offering new tools in the search of environmentally friendly processes. Finally, in a last part, we will demonstrate that glycerol can be considered as a promising renewably sourced co-solvent for the catalytic dehydration of fructose to 5-hydroxymethylfurfural. Possible scale up (1Kg scale) will be also discussed.

[1] as a recent review on this topic see Y. Gu, F. Jérôme, Green Chem. 2010, 7, 1127-1138

Glycerol/Water Phase as Green Reaction Media for Hydrophobic Bioactive Chelating.

Bachar Zebib, Zéphirin Mouloungui, University of Toulouse, France
bachar.zebib@ensiacet.fr

Solvents are used daily in numerous industrial processes as reaction medium, in separation procedures, and as diluters. As reaction medium, solvent are employed to bring reactants and/or catalysts together and to deliver heat and momentum . In addition, the solvent may also affect activity and selectivity. The choice of the solvent, i.e., its chemical, physical, and biological nature, also plays a key role from environmental, economic, safety, handling, and products isolation point of views. Water is the first solvent of choice regarding the aforementioned considerations, yet the negligible solubility of many organic and organo-metallic compounds in water limits its applications. Using organic, petroleum-based, solvents that allow dissolving a large variety of solid, liquids, and gases is usually accompanied with air, water, and land contamination. Fluorous phases and ionic liquids have been reported as recyclable environmentally benign reaction media but these solvents are non-biodegradable, toxic, and their production is also associated with use of high amounts of hazardous and volatile organic solvents. Supercritical fluids and especially supercritical water have also been reported as green solvents, but their high critical properties still limits their practical use.

In this communication, we investigate that the use of glycerol/water phase as solvent was able to considerably accelerate the reaction rate of an organic reaction even starting from more hydrophobic substrates than those usually used on water. Besides, we investigate the possible use of glycerol/water phase as green reaction medium to join reactants from two different worlds; organic and inorganic chemistry, in particularly, chelating reaction between bioactive compound and zinc metal ion from inorganic salts.

Acid catalyzed dehydration of glycerol to acrolein.

Andreas Martin, Hanan Atia, Udo Armbruster, Leibniz-Institut für Katalyse e.V, Rostock,
Germany
andreas.martin@catalysis.de

During the last decade, biodiesel (FAME – fatty acid methyl ester) production from plant oils (triglycerides) used as pure fuel or additive to diesel fuel (5.75 % regulation in EU) on large scale caused a surplus of by-product glycerol on the chemicals market. Therefore, intensive research efforts are under way to find new outlets for glycerol either for chemical utilisation or energy generation. In particular, the work on chemical valorisation of glycerol by oxidation, hydrochlorination, esterification, oligomerisation and dehydration has led to promising results [1]. New processes have been realised very recently, e.g. Solvay S.A. commercialised the conversion of glycerol into epichlorohydrin by Epicerol® process [2]. Glycerol dehydration to acrolein is an attractive sustainable alternative to the conventional acrolein process that uses propene stemming from fossil sources. It is feasible even in the presence of a surplus of water although raw glycerol impurities (salts, MeOH, etc.) may lead to rapid catalyst damages. The reaction has been studied in general with acidic catalysts. Among these catalysts were acids like H₂SO₄ and H₃PO₄, metal phosphates, sulphates, oxides, zirconia based materials and zeolites. Also heteropolyacids (HPA's) have been very recently evaluated by several research groups [e.g. 3,4], in particular commercially available 12-heteropolyacids with Keggin structure. Selectivities for acrolein above 70 % have been reported. However, the major drawbacks of heteropolyacids being applied in heterogeneously catalysed gas phase reactions are the limited thermal stability [5] and their low specific surface area (1-5 m²/g), in general. Nevertheless, some studies on long-term properties of such catalysts are available [e.g. 6], increased BET-surface areas were reached by using various oxidic supports [e.g. 3,4]. A very recent report claims the doping of heteropolyacid catalysts with noble metals and co-feeding of hydrogen during dehydration of glycerol leading to improvement of long-term properties and thus, deactivation resistance [7]. Otherwise, own studies on V-promoted HPA's used as catalysts in the dehydration in presence of small proportions of oxygen have shown that the presence of oxygen keeps the transition metals in a highly oxidized state that prevents fast deactivation by coking [8]. Main effect of alkaline metal addition can be seen in improved selectivity and activity, in particular with silica supported catalysts [9]. This contribution should give an extensive overview on the recent research carried out in the field of glycerol dehydration backed by our own work. Such experiments were mainly carried out on supported HPA's and HPA catalysts promoted by alkaline ions to modify acidity because acidity of the catalysts is crucial for their activity but unfortunately for deactivation by coking too.

References

- [1] A. Corma, S. Iborra, A. Velty, *Chem. Rev.* 107 (2007) 2411-2502.
- [2] M. McCoy, *Chem. Eng. News* 84 (2006) 7.
- [3] E. Tsukuda, S. Sato, R. Takahashi, T. Sodesawa, *Catal. Commun.* 8 (2007) 1349-1353.
- [4] H. Atia, U. Armbruster, A. Martin, *J. Catal.* 258 (2008) 71-82.
- [5] I.V. Kozhevnikov, *Chem. Rev.* 98 (1998) 171-198.
- [6] U. Armbruster, H. Atia, A. Martin, *Chem.-Ing.-Tech.* 82 (2010) 1203-1210.
- [7] A. Alhanash, E.F. Kozhevnikova, I.V. Kozhevnikov *Appl. Catal. A* 378 (2010) 11-18.
- [8] S. Erfle, U. Armbruster, U. Bentrup, A. Martin, A. Brückner, *Appl. Catal. A* (2011), in press.
- [9] H. Atia, U. Armbruster, A. Martin, *Appl. Catal. A* (2011), in press.

New isomerizing transformations with unsaturated fatty acids

Lukas J. Gooßen, Dominik M. Ohlmann, Technische Universität Kaiserslautern, Kaiserslautern, Germany; Markus Dierker, Care Chemicals Technology, Cognis GmbH, Düsseldorf, Germany
ohlmann@chemie.uni-kl.de

Double-bond migration is often encountered as an unwanted side reaction in metal catalyzed transformations. However, it can open up new synthetic opportunities when induced in a controlled way. When combined with an irreversible reaction step that selectively removes certain double-bond isomers from a dynamic equilibrium, new isomerizing functionalizations become possible. So far, this concept has been realized for reactions only at the omega-carbon of unsaturated fatty acid derivatives. [1]

We developed highly active bifunctional catalysts for isomerizing functionalizations of unsaturated carboxylic acids or esters at other chain positions than the omega-carbon. It is demonstrated that free fatty acids can be selectively converted into valuable saturated gamma-lactones in the presence of a silver catalyst, which mediates the double-bond migration and at the same time facilitates the addition of the carboxylate group to the double-bond once it is in the gamma-position. [2]

A second process is presented which allows the synthesis of beta-aryl or beta-amino esters via isomerizing conjugate addition of nucleophiles to unsaturated esters. This unprecedented reaction is catalyzed by a rhodium/phosphite system and can be applied to a range of unsaturated esters with various chain lengths and double-bond positions. [3]

References:

- [1] a) K. Y. Ghebreyessus, R. J. Angelici, *Organometallics* 2006, 25, 3040–3044. b) C. Jiménez-Rodríguez, G. R. Eastham, D. J. Cole-Hamilton, *Inorg. Chem. Commun.* 2005, 8, 878–881. c) C. Jiménez-Rodríguez, G. R. Eastham, D. J. Cole-Hamilton *Chem. Commun.* 2004, 1720–1721. d) D. Quinzler, S. Mecking, *Angew. Chem.* 2010, 122, 4402–4404. e) A. Behr, D. Obst, A. Westfechtel, *Eur. J. Lipid Sci. Technol.* 2005, 107, 213–219.
- [2] a) L. J. Gooßen, D. M. Ohlmann, M. Dierker, *Green Chem.* 2010, 12, 197–200. b) L. J. Gooßen, D. M. Ohlmann, M. Dierker, T. Löhl, patent EP 22411562, 2009.
- [3] a) L. J. Gooßen, D. M. Ohlmann, M. Dierker, patent application, 2010. b) L. J. Gooßen, D. M. Ohlmann, M. Dierker, submitted, 2011.

Epoxidized Sucrose Ester Resins: A New Highly Functional Biobased Epoxy Resin for Thermosets.

Dean Webster, Partha Sengupta, Xiao Pan
North Dakota State University, Fargo, ND, USA
dean.webster@ndsu.edu

While interest in the development of materials based on renewable resources continues to grow at a rapid pace, in many cases it has been challenging to obtain materials having properties comparable to that of the current petrochemical-based materials. This has been especially true for materials based on vegetable oils since the aliphatic nature of the fatty acid chains can result in soft materials even after crosslinking. One potential method for improving the performance is to increase the functionality of the precursors to obtain a higher crosslink density in the corresponding thermoset. Thus, highly functional biobased epoxy resins were synthesized by the epoxidation of sucrose esters of vegetable oil fatty acids. The epoxidized sucrose esters (ESEs) are colorless liquids having moderate viscosity. Depending on the degree of esterification of the sucrose moiety and the composition of the fatty acid (linseed, safflower, soy), the resins can have epoxy functionalities ranging from 8 to 15 epoxy groups per molecule, significantly higher than that of epoxidized vegetable oils. This high degree of epoxy functionality can translate into high crosslink density of thermosets derived from the epoxidized sucrose ester resins. For example, cationic photopolymerization of the ESE resins resulted in hard coating films having good solvent resistance. Photopolymerization rate was significantly higher than that of epoxidized soybean oil. Further, thermal crosslinking of the ESE resins using anhydrides resulted in materials having high tensile strength and good toughness. The properties could be varied depending on the ESE resin used, the relative epoxy to anhydride stoichiometry, and the degree of esterification of the sucrose ester resin. These systems can have applications as coatings, adhesives, and composite matrix resins.

Epoxidation of methyl oleate over Ti(IV) -grafted silica catalysts with hydrogen peroxide.

Elena Gavrilova,¹ Matteo Guidotti,¹ Rinaldo Psaro,¹ Anne Galarneau,² Nicoletta Ravasio,¹
¹ Università degli studi di Milano, Milano, Italy; ² Institut Charles Gerhardt Montpellier, France
elena.gavrilova@unimi.it

Epoxides of fatty acid methyl esters (FAMES) are an important class of chemicals finding various applications as intermediates in the production of commercially important products and materials. Nowadays, in industrial processes, epoxides of FAMES are generally obtained in homogeneous phase by the Prileshajev reaction, using peracetic or performic acids generated *in situ* [1]. However, the process presents some drawbacks. Thus, during last decades, several studies have been performed searching for an active catalytic system for the epoxidation of FAMES using hydrogen peroxide and avoiding the use of peroxyacids. So far, the maximum yield of 54% in the reaction of methyl oleate epoxidation with hydrogen peroxide was reached [2] with a high oxidant to substrate ratio over alumina-based systems. Some of us have shown that Ti(IV)-grafted silica catalysts are efficient catalysts for the epoxidation of fatty acid methyl esters with TBHP [3]. In this report, we have applied the experimental protocol of the slow dropwise addition of H₂O₂ (aq. 50%), previously used in the reaction of cyclohexene epoxidation [4], to the epoxidation of methyl oleate.

Table 1. Catalytic behaviour of Ti-silica catalysts in the epoxidation of methyl oleate.

Entry	Catalyst	Conv 24h (%)	Select EPOX 24h (%)	Select ENOL 24h (%)	Select KETO 24h (%)	Y 24h (%)	Cis/trans EPOX ratio	Oxidant efficiency
1	Ti/MCM-41	52	83	11	6	43	80:20	39
2	Ti/MCM-48	52	78	12	10	41	72:28	39
3	Ti/Aerosil	47	83	13	10	39	78:22	38
4	Ti/DavC	51	52	33	15	27	33:67	39
5 ^a	Ti/MCM-41	82	68	5	3	75	74:26	20
6 ^b	Ti/MCM-41	96	94	3	3	91	85:15	73

Reaction conditions: 1.5 mmol methyl oleate, 2 mmol H₂O₂ (50%), 50 mg catalyst, CH₃CN, 24 h, 85°C;

^a 200 mg of catalyst, 6 mmol H₂O₂, ^b 400 mg of catalyst.

The epoxidation tests have been performed in liquid phase in batch reactor with Ti-grafted on: 1) ordered mesoporous (MCM-41 and MCM-48), 2) non-ordered (SiO₂-DavC) mesoporous, and 3) on nonporous silicas (Aerosil). The combination of H₂O₂ and CH₃CN with either porous or nonporous Ti-grafted silicas gave interesting results in terms of selectivity towards methyl epoxystearate with a yield of 40% (Table 1). By gradually increasing the amount of catalyst, it was possible to increase the yield from 43% up to 91%, the formation of *cis* epoxide being always prevalent over the formation of *trans* isomer. Combination of larger amounts of catalyst and an excess of H₂O₂ leads to yields up to 91% to methyl epoxystearate. Such results (with epoxide yield from ca. 70% to ca. 90%) are the highest data obtained in literature so far over Ti-silica mesoporous catalysts with hydrogen peroxide.

[1] Z.S. Petrovic, A. Zlatanic, C.C. Lava, S. Sinadinovic-Fiser, *Eur. J. Lipid. Sci. Technol.*, **2002**, 104, 293

[2] P.A.Z. Suarez, M.S.C. Pereira, K.M. Doll, B.K. Sharma, S.Z. Erhan, *Ind. Eng. Chem. Res.*, **2009**, 48, 3268.

[3] M. Guidotti, R. Psaro, N. Ravasio, M. Sgobba, E. Gianotti, S. Grinberg, *Catal. Lett.*, **2008**, 122, 53

[4] M. Guidotti, C. Pirovano, N. Ravasio, B. Lázaro, J. M. Fraile, J. A. Mayoral, B. Coq, A. Galarneau, *Green Chem.*, **2009**, 11, 1421.

The authors gratefully acknowledge NANO-HOST European NoEs for financial support.

Synthesis of Oleochemical Derivatives via Zinc (II) perchlorate hexahydrate Catalysed Ring Opening Reactions and Co-halogenation on Olefinic Fatty Substrates.

Sukhprit Singh, Avinash Bhadani, Raman Kamboj, Bhupinderpal Singh, Department of Chemistry, Guru Nanak Dev University, Amritsar, India.
sukhprit@gmail.com

Oils and fats are an important source of renewable raw materials available for synthesis of major industrial chemicals. With the continuous increase in prices of petrochemical feed stocks and urgent need for synthesis of bulk industrial chemicals via sustainable and green approach to deal with the complex issues of global warming. New and alternative synthetic routes need to be developed to derive oleochemical derivatives for industrial applications. Derivatization of fatty acids, epoxy ring containing fatty acids and unsaturated fatty acids, gives us a convenient source of starting materials for the synthesis of various biodegradable derivatives. They can give rise to many types of surfactants and lipids that can modify properties at the interface. Our research group has reported catalytic epoxy ring opening reactions for the synthesis of glycol ethers¹ and β -amino alcohols² from epoxy ring containing fatty acid methyl esters. Similarly several new oleochemical derivatives such as β -haloethers,³ β -haloethoxylates,⁴ β -halothioethoxylates,⁵ β -haloesters,⁶ β -bromo glycerol monoethers⁷ and glycerol based cationic surfactants⁸ have also been reported by using co-halogenation methodology. With the continuation of our work several new β -amino alcohols and surfactants have been developed by Zinc (II) perchlorate hexahydrate catalysed ring opening reactions and co-halogenation methodology utilizing 10-undecenoic acid methyl esters and long chain fatty alcohols. These new derivatives have been characterized by several spectroscopic techniques (NMR, IR, Mass Spectroscopy and Elemental Analysis) and evaluated for their surface and biological properties.

- 1) Singh, S., Synthesis of Oligoethylene Glycol Ethers from the Seed Oil of Vernonia anthelmintica. J. Am. Oil Chemists' Society, 1997 74 609-611.
- 2) Singh, S., Kamboj, R., Synthesis of β -Amino Alcohols from Methyl Epoxy Stearate. Ind. Eng. Chem. Res. 2010 49 3106–3111.
- 3) Ahmad, I., Singh, S., Use of N-bromosuccinimide to obtain 1,2-bromocarboxylates from olefinic fatty methyl esters. J. Oil Technol. Assoc. India (Kanpur, India) 1995 27 215-220.
- 4) Singh, S., Singh, B., Synthesis of β -Bromoethoxylates and β - Chloroethoxylates from olefinic fatty methyl esters. J. Surfactants Detergents. 2006 9 51-56.
- 5) Singh, S., Singh, B., N-Halosuccinimide-mercaptoethanol cohalogenation of olefinic fatty methyl esters: synthesis of β -halo thiothloxylates. J. Surfactants Detergents. 2006 9 191-195.
- 6) Singh, S., Bhadani, A., Singh, B., Synthesis of wax esters from α -olefins. Ind. Eng. Chem. Res. 2007 46 2672 - 2676.
- 7) Singh, S., Bhadani, A., Kamboj, R., Synthesis of β -Bromoglycerol monoethers from α -olefins. Ind. Eng. Chem. Res. 2008 47 8090–8094.
- 8) Singh, S., Bhadani, A., Kataria, H., Kaur, G., Kamboj, R., Synthesis of Glycerol-Based Pyridinium Surfactants and Appraisal of their Properties. Ind. Eng. Chem. Res. 2009 48 1673-1677.

Production, Technologies and Applications of Fatty Alcohols.

Klaus Noweck, Brunsbüttel, Germany
klaus@noweck.com

The lecture will introduce into the technologies to produce fatty alcohols, describe the installed world wide production capacities and focus on the main applications.

Fatty alcohols are defined as aliphatic alcohols with chain lengths between C6 and C22. They are predominantly linear and monohydric, and can be saturated or have one or more double bonds. Alcohols with a carbon chain length above C22 are referred to as wax alcohols. Diols whose chain length exceeds C8 are regarded as substituted fatty alcohols. The character of the fatty alcohols (primary or secondary, linear or branched-chain, saturated or unsaturated) is determined by the manufacturing process and the raw materials used. Natural products, such as fats, oils, and waxes, and the Ziegler alcohol process provide linear, primary, and even-numbered alcohols; those obtained from natural sources may be unsaturated. In contrast, the oxo process yields 20 – 60 % branched fatty alcohols, and also some odd-numbered ones. Guerbet dimerization results in β -branched, primary alcohols, whereas Bashkirov oxidation yields secondary alcohols.

Depending on the raw materials used, fatty alcohols are classified as natural or synthetic. Natural fatty alcohols are based on renewable resources such as fats, oils, and waxes of plant or animal origin, whereas synthetic fatty alcohols are produced from petrochemicals such as olefins and paraffins. Up to 1930, when catalytic high-pressure hydrogenation was developed by ADKINS and FOLKER, NORMAN, SCHRAUTH and SCHMIDT, the manufacture of fatty alcohols was based almost exclusively on the splitting of sperm oil. By 1962, the world production capacity from natural raw materials had grown to ca. 200 000 t/a. New processes utilizing petrochemical raw materials, e.g., the Ziegler alcohol process, the SHOP process, the oxo process, and the construction of additional plants for high-pressure hydrogenation of natural raw materials, allowed a further increase. In 2005, the world nameplate production capacity of fatty alcohols was estimated to be $2,2\text{--}2,5 \times 10^6$ t/a, being nearly equally based on natural and petrochemical feedstock. This ratio changed because 600-700.000 t/a additional production capacity based on natural feedstock came or will come on stream by 2012. Even crude oil exporting countries like Saudi Arabia decided to install a natural based fatty alcohol plant. Production and consumption were estimated to amount to only approx. 70% and less of the installed capacity. Fatty alcohols and their derivatives are used at about 80% in surfactants and in addition in polymers, oil additives, cosmetics and have many specialty uses.

Abstracts

Part 2: Posters

Synthesis and characterization of esters derived from ricinoleic acid and evaluation of their low temperature properties

Nadia Salih,¹ Jumat Salimon,¹ Emad Yousif,² ¹School of Chemical Sciences & Food Technology, Faculty of Science and Technology, Universiti Kebangsaan Malaysia; ² Department of Chemistry, College of Science, Al-Nahrain University, Baghdad, Iraq.
nadiaas@ukm.my

This paper presents a series of structures derived from ricinoleic acid to be used as biolubricants. The resulting products were confirmed by NMR and FTIR analysis. The synthesis is carried out in three stages: (1) epoxidation of ricinoleic acid; (2) synthesis of 10,12-dihydroxy-9-acyloxystearic acid from epoxidized ricinoleic acid; (3) esterification of the acyloxystearic acid products with octanol to yield octyl-10,12-dihydroxy-9-acyloxystearate. The viscosities, flash points and pour points (PP) behavior of the products were measured. The resulting esters had an increased molar weight and viscosity as compared to ricinoleic acid and decreased the pour points.

P2

Saponification Method for Carotene Extraction from Red Palm Oil

Yousef Fazli, Parisa Kermani, Islamic Azad University- Arak Branch, Arak,
Islamic Republic of Iran
y_fazli@yahoo.com

Food Colorants may be classified into synthetic, natural identical and natural colorants. Most often the colorants extracted from plants. Crude palm oil has a deep orange-red color contributed by high carotene content 500 to 700 ppm which 90% consist of alpha and beta carotene. Carotene is recovered from a palm oil in two process steps. This experiment is based on the recovery of carotene from red palm oil through saponification, drying and solvent extraction.

P3

^{13}C NMR AND ^1H NMR SPECTROSCOPIC ANALYSIS OF ADANSONIA DIGITATA, ALBIZIA LEBBECK AND DANIELLIA OLIVERI OILS

Habeebat O. Adubiaro,¹ Olorunfemi O. Olaofe,² Emmanuel T. Akintayo,² Cecilia O. Akintayo,² ¹Science Technology Department, Federal Polytechnic, Ado – Ekiti. Nigeria; Chemistry Department, University of Ado – Ekiti, Ado – Ekiti . Nigeria.
hadubiaro@yahoo.com

Three different vegetable oils of *Adansonia digitata*, *Albizia lebeck* and *Daniellia oliveri* were studied using ^{13}C NMR and ^1H NMR. The gated decoupled high resolution ^{13}C NMR Spectra revealed the presence of both saturated and unsaturated triacylglycerides in the oil samples, however with higher percentage of unsaturation in *Albizia lebeck* seed oil. The peaks at 0.7 to 0.9 ppm which correspond to the terminal methyl groups in the fatty acid and that at 1.2 to 1.3 ppm are more intense and bigger in *Daniellia oliveri* which show that it is more saturated than *Adansonia digitata* and *Albizia lebeck* oils. The results obtained by ^{13}C NMR and ^1H NMR compared favourably with those obtained by gas chromatographic analysis.

Renewable Gemini Cationic Surfactants: Synthesis and Evaluation of their Surface Properties

Avinash Bhadani and Sukhprit Singh*

Department of Chemistry, Guru Nanak Dev University, Amritsar, India.

avinashbhadani2003@yahoo.co.in

Environmental concerns have made the development of new surfactants based on renewable feed stocks with a specific emphasis on non-conventional raw materials (i. e - non-food crops and agricultural waste)¹ more or less obligatory. Cationic surfactants are important category of surface active agents which are being used in countless application areas. Gemini surfactants are a new generation of surfactants which have much lower critical micelle concentration (cmc) values than their monomeric counterparts. Recently, we have reported novel series of gemini pyridinium surfactants by cobromination protocol.² With the continuation of our work several new renewable gemini surfactants based on 10-undecenoic acid – an important industrial feed stock derived from castor oil has been synthesized by energy saving and cost effective methodology. 10-undecenoic acid methyl esters were reacted by cobromination protocol to get gemini dibromo containing intermediates which were reacted with different heterocyclic moieties to get corresponding renewable gemini surfactants. These new gemini surfactants have been characterized by several spectroscopic techniques (i. e - NMR, IR and Mass Spectroscopy) and have been evaluated for their surface properties i .e – critical micelle concentration (cmc), C₂₀ (surfactant concentration required to reduce the surface tension of the solvent by 20 mN·m⁻¹), Γ_{max} (maximum surface excess), A_{min} (minimum surface area per molecule).

- 1) Non-conventional surfactants from amino acids and glycolipids: Structure, preparation and properties. Ma Rosa Infante, Aurora Pinazo and Joan Seguer, *Colloids and Surfaces A: Physicochemical and Engineering Aspects*, 1997, 123-124, pp 49-70.
- 2) Novel Gemini Pyridinium Surfactants: Synthesis and Study of Their Surface Activity, DNA Binding, and Cytotoxicity. Avinash Bhadani and Sukhprit Singh, *Langmuir*, 2009, 25 (19), pp 11703–11712.

P5

Modelling of critical fluids process for adding value and functionality to sunflower oil.

Muhammad Baig,¹ Regina Santos,² Steve Bowra,³ Daniel Pioch¹

¹ CIRAD-Persyst, 34398 Montpellier, Cedex 5, France; ² Department of Chemical Engineering, University of Birmingham, UK; ³ Phytatec UK Limited, UK
m.n.baig@bham.ac.uk

The European Technology Platform for Sustainable Chemistry in its Strategic Research Agenda of 2006 developed three visionary project ideas. One stated vision was integrated biorefining, which was defined as a process that would enable the production of platform chemicals, material and biofuels from biomass and ideally in a sustainable manner. Critical fluids offer environmental advantages over chemical solvents, while providing enhanced separation, and chemical selectivity. Therefore our objective is to establish the use of critical fluids for recovering multiple products from biomass and combine this with transformation of selected molecules to add value. To achieve this overall objective we have begun by selecting sunflower oil as a model substrate. As a first step, the conversion of sunflower vegetable oil (Triglycerides) in sub-critical water (SCW) was studied in a continuous flow reactor. In the second step of the process, FFA's were bio-catalytically transformed to fatty acid esters using lipase within supercritical fluid carbon dioxide environment. A factorial and a central composite design was used to evaluate the influence of operating conditions on the hydrolysis of oil as well as enzymatic esterification efficacy. The response surface equation was used to identify the optimum process conditions which maximised fatty acid ester yield. In summary we will present optimised process conditions for continuous flow SCW hydrolysis of sunflower oil and the subsequent transformation of Fatty acid to ethyl esters. We will also discuss the process advantages of coupling the two steps to one continuous flow unit and the power of RSM modelling in assisting process development.

P6

Effect of harvest periods on some properties of olive oils obtained from several olive varieties

Ayhan Dağdelen¹, Gülendamar Tümen², Mehmet Musa Özcan³, Ekrem Dündar²

¹ Vocational High School, Food Technology, Balıkesir University Bandırma-Balıkesir;

² Department of Biology, Faculty of Science and Education, Balıkesir University Bandırma-Balıkesir; ³ Department of Food Engineering, Faculty of Agriculture, University of Selçuk,

Konya, Turkey

mozcan@selcuk.edu.tr

Effect of ripening on quality of olive oils of several olive varieties. Oil contents of olive varieties ranged between 2.54% (Domat) to 31.86 % (Gemlik). The oil contents of all varieties increased from August to December during ripening periods. The major fatty acids were oleic, palmitic and linoleic acids. Oleic acid is the main monounsaturated fatty acid, with high levels (59.10-75.33%) according to varieties. The highest variations were found in oleic and linoleic acids during ripening periods. Linolenic acids were found lowest in all variety oils. It was found significantly at the $p < 0.01$ levels among varieties for 100 fruit weights, fruit number, pulp/seed, moisture, pulp% values, and at the $p < 0.05$ for oil contents. According to statistical analysis, fatty acid compositional differences among the oils studied were significant, indicating a varietal effect on olive oil quality.

Composition and characteristics of some seed oils

Ahmet S. Erol¹, Mehmet M. Özcan², Fatih Er¹, M. Uğur Yıldız³

¹ Selcuk University, Cumra High Educational College, Cumra-Konya/ Turkey;

² Department of Food Engineering, Faculty of Agriculture, Selcuk University, Konya-Turkey; ³ Open and distance education faculty İstanbul University Centre Campus

Beyazıt/Eminönü-İstanbul

Uyildiz202@hotmail.com

Physico-chemical characteristics and fatty acid composition of some seed oils (corn, cotton, olive, poppy, pumpkin, rape, safflower, sunflower, tea seed, walnut and wheatgerm) were determined using the methods of the American Oil Chemists Society. The oil content of samples ranged from 10.73% (wheatgerm) to 61.3 % (walnut). Refractive index, relative density, saponification and Iodine values were determined in the seed oils. The main fatty acids identified by gas chromatography were palmitic, oleic and linoleic acids. The linoleic acid content of oils were found high compared with other acids.

Photo curable castor oil based highly hydrophobic coatings

Yusuf Mülazim, Emrah Çakmakçı, Memet Vezir Kahraman, Nilhan Kayaman Apohan
Marmara University, Department of Chemistry, Istanbul/Turkey
emrah.cakmakci@marmara.edu.tr

Modification and use of natural products have gained a lot of interest in recent years due to their environmental friendliness and their availability from different sources. Castor oil (CO) is an inexpensive, environmental friendly, renewable and a naturally occurring vegetable oil with low toxicity and having free secondary hydroxyl groups [1,2]. In this study castor oil based photo curable highly hydrophobic coatings were prepared and characterized. Castor oil (CO) was first modified with 3-isocyanato propyl triethoxy silane and then it was hydrolyzed prior to the coating preparation. The resulting precursor was mixed with norbornyl acrylate, hexane diol diacrylate and hydrophobic coatings were prepared with the aid of fluorinated and nonfluorinated alkoxy silane coupling agents. As the fluorine content was increased in the formulations, flame retardancy and the contact angle values of the coatings increased. The highest amount of fluorine containing coating showed a contact angle of 119°. Then with the addition of nonfluorinated alkoxy silane compounds, a contact angle of 130° was reached. Also the effect of post-cure temperature on contact angle values was investigated.

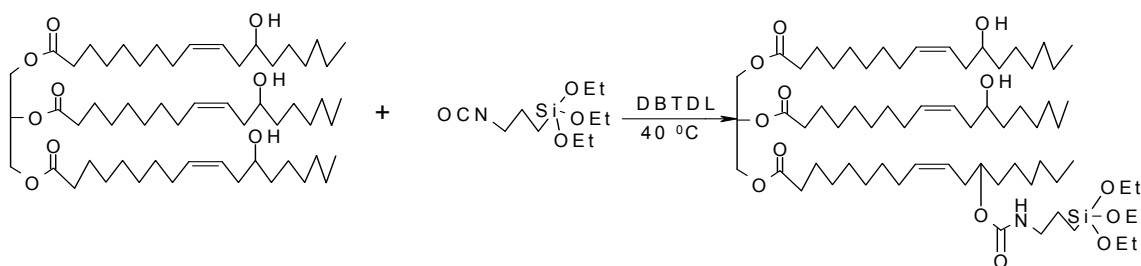

References:

- [1] M.A. Corcuera, L. Rueda, B. Fernandez d'Arlas, A. Arbelaiz, C. Marieta, I. Mondragon, A. Eceiza, *Polym. Degrad. Stab.* 95 (2010) 2175.
[2] A. Palanisamy, B.S. Rao, *Prog. Polym. Sci.* 60 (2007) 161.

PHYSICO CHEMICAL AND FATTY ACIDS COMPOSITION OF SOME LEGUME SEED OILS

Henry Niyi Ogungbenle, O. Olaofe, B. E. Akhadelor, A. O. Idris, O. V. Omojola,
O. T. Omotehinse, O. A. Ogunmodede,
University of Ado-Ekiti, Nigeria
htphenryo@yahoo.com

The Physicochemical properties and proximate and fatty acids compositions of calabash , bottle gourd , lump-in-neck gourd ,Citrullus lunatus and Citrullus colocynthis kernel have been investigated. The studies showed that calabash kernel has the highest amount of protein (35.9%).The ranges of the physicochemical properties are: acid value (4.59 – 5.92mgKOH/g oil), peroxide value (5.63 – 6.63mgKOH/kg), refractive index (1.46-1.52), iodine value (40.2 – 153mg/100g), specific gravity (0.90 – 0.94) free fatty acid (ffA) (2.30 – 2.96mgKOH/g) and saponification value (159 – 225mgKOH/g). The increasing order of concentration of fatty acids is linoleic acid (20.20 – 65.80%) > oleic (16.6 – 58.2% > palmitic (0.02 – 12.9%) > stearic acid (0.10 – 9.58%). The samples contained small quantities of palmitoleic, capric and linolenic acids.The results obtained from the analyses indicate that the under utilised legume seed oils are important feedstocks for chemical industries.

Synthesis of β -Amino Alcohols from 10,11-Epoxy Methyl Undecanoate

Raman Kamboj and Sukhprit Singh*

Department of Chemistry, Guru Nanak Dev University, Amritsar, 143 005, India
kambyraman@gmail.com

Oleochemistry is a well-founded and well-developed branch of chemistry, exploited extensively for the manufacturing of fat-derived chemicals essential to a variety of industrial areas; such as protective coatings, surfactants, plasticizers, lubricant additives, cosmetics, pharmaceuticals, soaps, detergents, textiles, plastics, organic pesticides, urethane derivatives and a variety of synthetic intermediates. The ever-increasing cost of petrochemicals has diverted the attention of chemists to the synthesis of new oleochemicals.¹

β -Amino alcohols are an important class of organic compounds,² the moiety is found in a wide variety of biologically active alkaloids and peptides.³ It finds applications, as a building block in the organic synthesis of various natural products and pharmaceuticals.⁴ They are easily converted to many other molecules, including amino acids and amino sugars.⁵ Oils and fats are an important source of renewable raw materials and availability of functionalized fatty acids such as epoxy ring containing fatty acids give us a convenient source of starting materials for the synthesis of various biodegradable derivatives. Recently, we have reported the synthesis of a series of β -Amino alcohols from methyl epoxy stearate.⁶ In continuation of our work, we here wish to report solvent free methodology for the synthesis of several β -amino alcohols from terminal epoxy fatty acid methyl esters by regioselective catalytic epoxy ring opening reaction using zinc perchlorate hexahydrate as a catalyst.

References

- (1) Hosamani, M. K.; Sattigeri, M. R. *Ind. Eng. Chem. Res.* **2005**, *44*, 254-260
- (2) Azizi, N.; Saidi, M. R. *Org. Lett.* **2005**, *7*(17), 3649-3651.
- (3) Olofsson, B.; Somfai, P. *J. Org. Chem.* **2002**, *67*, 8574-8583.
- (4) Reddy, L. R.; Reddy, M. A.; Bhanumathi, N.; Rao, K. R. *New J. Chem.* **2001**, *25*, 221-222.
- (5) Casiraghi, G.; Zanardi, F.; Rassa, G.; Spanu, P. *Chem. Rev.* **1995**, *95*, 1677.
- (6) Singh, S.; Kamboj, R. *Ind. Eng. Chem. Res.* **2010**, *49*, 3106-3111.

Simulation of Fatty Acid Esterification Using Reactive Distillation Process for Biodiesel Production

Ratna Dewi Kusumaningtyas^{1,2}, Mauro Banchero¹, Arief Budiman², Giuseppe Gozzelino¹
¹Dipartimento di Scienza dei Materiali e Ingegneria Chimica, Politecnico di Torino, Torino, Italy ²Chemical Engineering Dept., Universitas Gadjah Mada, Yogyakarta, Indonesia
dewinino@gmail.com

Biodiesel is one promising alternative energy source holding sustainable characteristic combined with high performance and environmental benefits. It is obtained from triglycerides of animal fats and plant oils. From the economic point of view, the less expensive feedstocks such as waste cooking oil or non-edible oil, usually contain high amount of free fatty acid (FFA). However, the current commercial technology, the alkaline-catalyzed batch transesterification, is not suitable for these materials. It is due to the fact that the FFAs and water, present in these raw materials, react with the alkaline catalyst to form soaps, thus consuming the catalyst, reducing the biodiesel yield and hindering the product separation. The undesired presence of FFAs can be reduced by a pre-treatment process based on acid-catalyzed esterification. Furthermore, beside being applied for an oil pre-treatment, the fatty acid esterification can play an important role in the biodiesel production. Recently, a new approach through a two-step process has been developed. It consists in the hydrolysis of triglycerides in subcritical water (first step) and the subsequent methyl esterification of fatty acids (second step) in supercritical methanol (Saka-Dadan process). In this way, the fatty acid esterification can become a fundamental step in the future production of biodiesel and the process intensification can have a key role in the industrial application. Esterification of FFA using the conventional batch process faces a challenge since it is low in productivity, requires high excess of reactant (alcohol), and needs a series of separation steps. Thus, it is not efficient for a large-scale production. To overcome this problem, the development of multifunctional reactors, which couple chemical reaction with the in situ separation of products from the reactants, can be considered. Reactive distillation (RD) is one among the most attractive processes for in situ product removal, which can provide potential benefits to the esterification reaction. RD is a hybrid process integrating the reaction and separation in a single column. It usually consist of three sections: reactive, rectifying, and stripping zones. To obtain an optimal design of the RD process, an accurate modelling and simulation of the process is crucial. In this work, simulation of heterogeneous-catalyzed oleic acid esterification using the RD process was conducted. The simulation was carried out using the ASPEN Plus V 7.1 Process Simulator based on the equilibrium stage model (EQ). Oleic acid was selected as a model compound since it is one of the major component of the oil feedstock for biodiesel plants. However, no details about the performance of a catalytic reactive distillation column for the oleic acid esterification are currently available in the open literature, only some experimental and simulation data of decanoic acid esterification can be found. Hence, the validity of the RD simulation procedure was tested by comparing the simulation results of decanoic acid esterification with the experimental data reported in the literature. It was shown that the simulation result of this study was close to published experimental data. The simulation of oleic acid esterification using RD was subsequently performed based on the EQ stage model, while the necessary kinetic data were obtained from the literature. In this simulation, sensitivity analysis was conducted to evaluate the influence of the process parameters on the reaction conversion, including the ratio of methanol to oleic acid in the feed stream, distillate rate, reflux ratio, total number of stages and feed point location.

Thiol-ene vs. ADMET: a complementary approach to fatty acid-based biodegradable polymers

Oğuz Türünç^{1,2}, Michael A. R. Meier²

¹ Hochschule Emden/Leer, Emden, Germany; ² KIT, Karlsruhe, Germany
oguz.turunc@student.kit.edu

The use of fatty acids as building blocks for biodegradable polymers introduces flexibility, low melting temperatures, hydrophobicity, pliability, and other interesting features into the thus derived materials.[1] The two major classes of biodegradable polymers are polyesters and polyanhydrides, which undergo bulk and surface erosion degradation, respectively. Typical fatty acid-based polyanhydride syntheses, widely studied by Domb et al., involves condensation reactions that need high temperatures and a vacuum in order to force the reaction towards polymerization, multiple steps and/or solvents.[2]

Thiol-ene click and ADMET polymerization reactions have become two outstanding tools for polymer scientists for the syntheses of plant oil derived polymers.[3] Therefore, we applied these reactions for the polymerization of the two structurally similar fatty acid based monomers, which only differed by the ester and anhydride functionality, in order to establish and compare the efficiency of the mentioned methods for biopolymer syntheses. The polymers thus derived were evaluated via a set of hydrolytic stability essays in different conditions, e.g. acidic and enzymatic, in order to understand their degradation behavior.[4]

References:

- [1] M. Sokolsky-Papkov, A. Shikanov, N. Kumar, B. Vaisman and A. J. Domb, Bull. Isr. Chem. Soc., 2008, 23, 12-17.
- [2] J.P. Jain, M. Sokolsky, N. Kumar, A. J. Domb. Polym. Rev., 2008, 48, 156-191.
- [3] L. Montero de Espinosa and M.A.R. Meier, Eur. Polym. J. 2011, accepted.
- [4] O. Türünç and M.A.R. Meier, Green Chem., 2010, DOI: 10.1039/c0gc00773k

Novel Gemini Surfactants Based on Hydroxycarboxylic Acids

Rachid Ihizane, Hans-Josef Altenbach, Manfred P. Schneider, Bernd Jakob, Karsten Lange, Sukhendu Nandi, Bergische Universität Wuppertal, Wuppertal, Germany
rihizane@yahoo.de

The conversion of fatty acid chlorides with (L)-tartaric, malic and citric acid resulted in the easy formation of acylated hydroxycarboxylic acid anhydrides¹. We have shown that this class of anhydrides provides convenient entry into a variety of products. They readily react with natural or synthetic nucleophiles like alcohols, carbohydrates, amines and amino acids². A series of compounds were synthesized and characterized. Several of the resulting surfactants show interesting properties such as low CMCs and different foaming ability and stability. For practical use of the above synthesized Gemini surfactants were tested regarding their activities against a series of bacteria, fungi and yeast. Some of them showed promising properties^{3,4}.

1. Lange K, Schneider M P, DE 10 2006 014 732 A1

2. Lange K, Altenbach H J, Ihizane R, Jakob B, Schneider M P, WO/2009/100890

3. Altenbach H J, Ihizane* R, Jakob B, Lange K, Nandi S, Schneider M P and Yilmaz Z; J. Surfact. Deterg.; Synthesis and Characterization of Novel Surfactants: Combination Products of Fatty Acids, Hydroxycarboxylic Acids and Alcohols; 2010, 13, 399-407

4. Altenbach H J, Berger M, Jakob B, Ihizane* R, Laumen K, Lange K, Machmüller G, Müller S and Schneider M P ; Lipid Technology; Lipid modification of amino acids, carbohydrates and polyols; 2010, 22 (7), 155-158

Regioselective synthesis of β -aryl- or β -amino-substituted aliphatic esters via rhodium-catalyzed double bond migration / conjugate addition cascades

Lukas J. Gooßen, Technische Universität Kaiserslautern, Kaiserslautern/D; Dominik M. Ohlmann, Technische Universität Kaiserslautern, Kaiserslautern/D; Markus Dierker, Care Chemicals Technology, Cognis GmbH, Düsseldorf/D
ohlmann@chemie.uni-kl.de

The isomerizing one-pot functionalization of unsaturated carboxylic acid derivatives, i.e. the *in situ* formation of a certain double bond isomer via double bond migration and its selective functionalization out of the catalytic equilibrium, is an important strategy for the introduction of functionalities into the carbon chain. This concept has been realized for reactions only at the omega-carbon of unsaturated fatty acid derivatives, which are widely available at low cost from renewable feedstocks. [1]

We herein present a process, in which a constantly renewing equilibrium mixture of positional and geometrical double bond isomers of an unsaturated ester is established. Out of this mixture, the isomers having the double bond in conjugation with the carboxylate group are continuously removed *via* catalytic 1,4 additions (Michael additions). This reaction allows the synthesis of various beta-substituted aliphatic carboxylic esters. Depending on the choice of the nucleophile, both beta-amino esters and beta-arylated products can be synthesized in good to high yields.

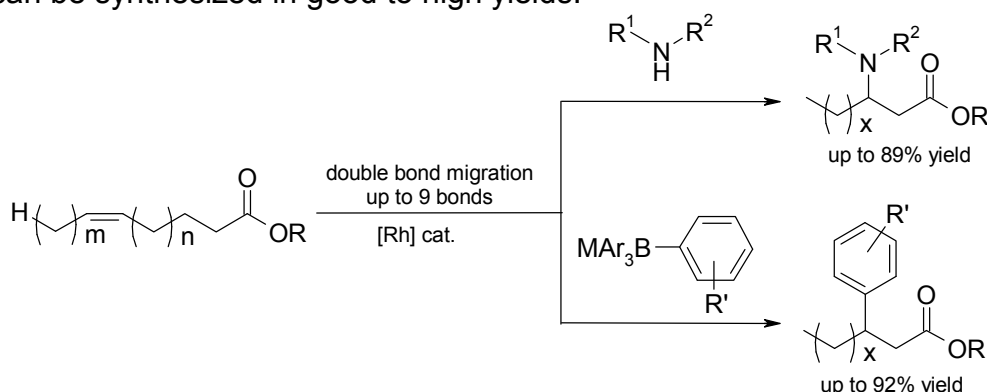

This way, a remote double bond is made accessible for manipulation using a commercially available rhodium complex and phosphite ligand under mild conditions. The applicability of both protocols was shown for a range of substrates, like fatty esters of different chain lengths and positions of the double bond, several arylborates and various primary and secondary amines as well as on a preparative scale experiment. [2]

References:

- [1] a) K. Y. Ghebreyessus, R. J. Angelici, *Organometallics* **2006**, *25*, 3040-3044. b) C. Jiménez-Rodríguez, G. R. Eastham, D. J. Cole-Hamilton, *Inorg. Chem. Commun.* **2005**, *8*, 878-881. c) C. Jiménez-Rodríguez, G. R. Eastham, D. J. Cole-Hamilton *Chem. Commun.* **2004**, 1720-1721. d) D. Quinzler, S. Mecking, *Angew. Chem.* **2010**, *122*, 4402-4404. e) A. Behr, D. Obst, A. Westfechtel, *Eur. J. Lipid Sci. Technol.* **2005**, *107*, 213-219.
 [2] a) L. J. Gooßen, D. M. Ohlmann, M. Dierker, M. Dörr, *patent pending*, b) L. J. Gooßen, D. M. Ohlmann, M. Dierker, *manuscript submitted*.

Aminolysis of glycerol carbonate in hydroorganic and organic medium

Bassam NOHRA, Laure CANDY, Zéphirin MOULOINGUI, Yann RAOUL
University of Toulouse, France
bassam.nohra@ensiacet.fr

Glycerol carbonate is one of the glycerol derivatives that captures at present more academic and industrial attention. Cyclic carbonates undergo number of reactions with various nucleophiles. The most explored reaction of cyclic carbonate has been that of aminolysis, that is, the reaction of cyclic carbonate with an amine. In the case of glycerol carbonate, this nucleophilic addition yields two hydroxyurethanes isomers. Using glycerol carbonate as reagent, α and β isomers were obtained in a ratio of 71/29 and 68/32 determined respectively by the classical ^1H NMR method and by a new HPLC method. It is well known that the decreasing demand for acrylonitrile results in a worldwide shortage of acetonitrile, the commonly used eluent in reversed phase chromatography. We then compared the efficiency of acetonitrile with the alternative eluent methanol, using C18 column. It has been demonstrated that methanol was appropriate to replace acetonitrile in the separation of isomers.

No studies have been yet reported in the literature describing the kinetics and the mechanism of the aminolysis reaction in hydroorganic medium and the formation of a candidate reaction (glycerol) in hydroorganic and organic medium. Our studies demonstrated that the aminolysis reaction is affected by the hydrolysis of glycerol carbonate and N-alkylurethane. This enabled us to study the behavior of this reaction in hydroorganic medium. The aminolysis of glycerol carbonate under aqueous conditions competes with the hydrolysis of glycerol carbonate and the N-alkylurethane. Several primary amines with various alkyl chain lengths ($\text{NH}_2\text{-C}_n\text{H}_{2n+1}$; $n=0, 4, 6, 8, 12$) were studied. Kinetic investigations revealed that in hydroorganic medium the rate of formation of glycerol decreased as the length of the alkyl chain increased. In contrary, in organic medium the length of the alkyl chain does not play major role in the formation of the hydrolysis product. Indeed, hydroorganic medium yields approximately 13% of glycerol whereas organic medium yields 9% of glycerol

Functionalization of fatty compounds via cross-metathesis and palladium catalyzed C-H activation

Marc von Czapiewski¹, Oliver Kreye², Michael A.R. Meier²

¹University of Potsdam, Karl-Liebknecht-Straße 24-25, Potsdam, Germany

²KIT, Institute of Organic Chemistry, Karlsruhe, Germany

m.a.r.meier@kit.edu

The major focus of this work was the catalytic functionalization of double bond of methyl 10-undecenoate **1**, which can be obtained by pyrolysis from castor oil.[1] This was achieved via cross-metathesis and palladium catalyzed C-H activation. The cross-metathesis of **1** was performed with *cis*-1,4-diacetoxybut-2-ene **2** to obtain in high selectivity and good yields an α,ω -unsaturated acetoxy methyl-ester **3** (Scheme 1).

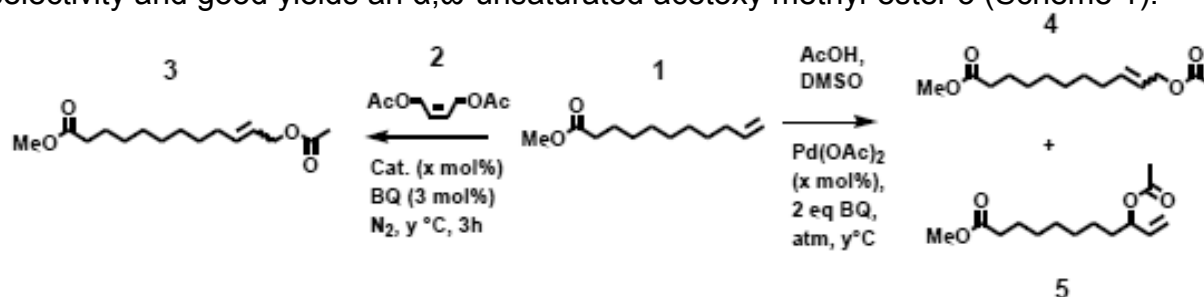

Scheme 1: cross-metathesis and palladium catalyzed C-H activation

The second catalytic method was performed with palladium(II)-acetate and acetic acid in DMSO as solvent. The catalyst system activates the allylic C-H bonds, followed by reaction with acetic acid.[2] The thus obtained products offer a linear **4** or branched **5** structure (Scheme 1). The achieved yields are good, but a lower selectivity in relation to cross-metathesis was observed.

References:

[1] H. Mutlu, M. A. R. Meier, *Eur. J. Lipid Sci. Technol.* 2010, 112, 10–30.

[2] Mark S. Chen, Narayanasamy Prabakaran, Nathan A. Labenz, and M. Christina White, *J. AM. CHEM. Soc.*, 2005, 127, 6970-6971.

Continuous production of 1,3-Propanediol using raw glycerol with immobilized *Clostridium beijerinckii* NRRL B-593 in comparison to suspended culture

Mine Gungormusler, Cagdas Gonen, and Nuri Azbar, Bioengineering Department,
Faculty of Engineering, Ege University, 35100 Bornova, Izmir, Turkey
nuriazbar@gmail.com

The continuous production of 1,3-Propanediol (1,3-PDO) was investigated with *Clostridium beijerinckii* NRRL B-593 using raw glycerol without purification obtained from a biodiesel production process. Ceramic rings and pumice stones were used for cell immobilization in a packed-bed bioreactor. For comparison purpose, a control bioreactor with suspended culture was also run. The effect of hydraulic retention time (HRT) on the production of 1,3-PDO in both immobilized and suspended bioreactors were also investigated. The study revealed that HRT is an important factor for both immobilized and suspended systems and a HRT of 2 h is the best one in terms of volumetric production rate (g 1,3-PDO/L.h). Furthermore, cell immobilization had also obvious benefits especially for the robustness and the reliability of the production. The results indicated that cell immobilization achieved a 2.5 fold higher productivity in comparison to suspended cell system. Based on our results, continuous production of 1,3-PDO with immobilized cells is an efficient method, and raw glycerol can be utilized without any pretreatment.

Sustainable production of plant-based plasticizers

S.C. Chua, J. Jimma, Z. Guo and X. Xu
Department of Molecular Biology, Aarhus University, Denmark
chua@md.au.dk

Traditional plasticizers derived from phthalic acid derivatives have raised a lot of health and environmental issues nowadays. With that reason, this study was carried too investigate the sustainable epoxidation method to produce plant-based plasticizers to substitute the phthalic based plasticizers. Besides being useful reactive building blocks for plastics, lubricants and surfactants industries, epoxidized plant based fatty acid esters are biodegradable and non-toxic up to a high concentrations. Therefore, epoxidized of natural based plasticizers will have a great future to replace chemical derivatives. In this work, comparison of enzymatic epoxidation of fatty acids esters in organic solvents and ionic liquids were carried out. The effects of different types of cation and anion in ionic liquids on the biocatalytic epoxidation were being studied.

Novel Polyglycerol-based Stimuli-responsive Hydrogels from Renewable Sources

Somaieh Salehpour and Marc A. Dubé
Department of Chemical and Biological Engineering
University of Ottawa, Ottawa, ON, Canada
ssale050@uottawa.ca

Growing interest in the use of renewable feedstocks derived from vegetable and animal sources has led to increased interest in the development of bio-based materials such as green monomers and biodegradable polymers. Glycerol as a bio-based monomer is an interesting candidate for a sustainable or “green” polymer production. Moreover, utilization of excess glycerol derived from the growing biodiesel industry is important to oleochemical industries. Recent research has focused on using glycerol as a platform chemical to replace mainstream petroleum- derived chemicals. Polyglycerol produced from glycerol consists of an inert polyether backbone with functional hydroxyl side groups which make it very suitable for the design of hydrogels. In this study, cross-linking of polyglycerol by multifunctional electrophilic compounds was investigated to achieve a controlled increase in polyglycerol molecular weight. Novel temperature and pH-responsive polyglycerol-based hydrogels were successfully synthesized and characterized. Hydrophilicity and biocompatibility of this hydrogel make it suitable for applications in the pharmaceutical, biomedical and biotechnological fields as hydrogel adhesives for wound dressing and drug delivery.

Novel polymeric materials derived from appropriately modified vegetable oils

Carla Vilela, Armando Silvestre, Alessandro Gandini
CICECO/Chemistry Department, University of Aveiro, Aveiro, Portugal
cvilela@ua.pt

This investigation represents the essential topic of the Doctorate Thesis of Ms Carla Vilela, which is one of several approaches carried out in our laboratory within the general strategy related to developing original materials derived from renewable resources, as an alternative to fossil based counterparts.

Among the possible working hypotheses considered when planning the course of this Thesis the following aspects have been tackled up to now, i.e., after about half of the time devoted to its completion:

1) The transvinilation of fatty acids with vinyl acetate. Although this reaction has been the subject of several studies in the past, it was essential in our context to attempt its implementation within a more “green” connotation, since all those studies privileged mercury salts as the catalyst for the reaction. In our work we showed that iridium-based compounds displayed an excellent catalytic activity, which allowed us to prepare macromonomers like vinyl palmitate (model compound), oleate and linoleate in good yields through a simple procedure. The idea here was to make use of the terminal vinyl moiety as the initial polymerizing function, mostly through free radical initiation, and to consider a subsequent slower evolution of the ensuing oligomers through their oxido-polymerization, and hence the formation of a crosslinked final material. This was successfully achieved with both vinyl oleate and vinyl linoleate, albeit with different setting kinetics, favouring the latter because of its higher degree of unsaturation [1].

2) After this first positive result, it was thought that it would be interesting to move to other polymerizable structures, including acrylic moieties for radical polymerization and vinyl ether counterparts for cationic activation. This phase of the Thesis is presently in full progress with different mechanistic approaches being tested.

The proposed poster will illustrate the essential points related to the various aspects evoked above.

References

[1] Vilela, C.; Rua, R.; Silvestre, A.J.D.; Gandini, A. *Ind. Crops Prod.* 2010, 32, 97.

Production of Microbial Lipids from Low-Cost Carbon Sources with the Yeast *Cryptococcus curvatus*

Ina Hein, Ines Schulze, Anke Neumann, Christoph Syldatk
KIT, Institute of Process Engineering in Life Sciences, Karlsruhe, Germany
ina.hein@kit.edu

Species of yeasts, molds, bacteria and microalgae which contain more than 20 % lipids in their cellular dry weight are also called oleaginous microorganisms. They produce single cell oils (SCOs) intracellularly in the stationary growth phase under nitrogen limitation with simultaneous excess of a carbon source. The amount of such storage lipids can reach up to 70 % of the cellular dry weight. Some oleaginous microorganisms are known to produce high proportions of polyunsaturated fatty acids (PUFAs) which are important for the food and cosmetic industry. The production of SCOs can be achieved from renewable resources and without competition with food or feed.

The aim of this study is the setup of a process for the economical production of SCOs with the model yeast strain *Cryptococcus curvatus*. For this purpose different low-cost carbon sources, including waste material containing carbohydrates, e.g. raw glycerol from biodiesel production or lignocelluloses waste material, are to be tested regarding to quantity and quality of the produced SCOs. Furthermore, the influence of process parameters (temperature, pH value, aeration, C/N-ratio) and the influence of amount and manner of nitrogen addition on the quality and quantity of the produced SCOs should be examined.

Design of Ru-Zeolites for Hydrogen-free Production of Conjugate Linoleic Acids and Conjugated Oils

An Philippaerts¹, Steven Goossens¹, Jan Geboers¹, Moniek Tromp², Stuart Turner³, Gustaaf van Tendeloo², Pierre Jacobs¹, Bert Sels¹, ¹K.U.Leuven, Heverlee, Belgium; ² TU München, Germany; ³ University of Antwerp, Antwerpen, Belgium
an.philippaerts@biw.kuleuven.be

Conjugated linoleic acids (CLAs) and conjugated vegetable oils are interesting compounds in the coatings, paints and polymer industries as well as in the food industry. As conjugated oils “dry” or polymerize more quickly than non-conjugated oils, they are very valuable for use in paints, inks and coatings [1]. Conjugated oils are also very reactive monomers for manufacturing of “bio-plastics” [2]. Finally, CLAs are also interesting from a nutritional point of view. Plenty of literature is available, describing the health benefits of CLAs [3]. While the isomer distribution is not important for the industrial applications (drying oils and bio-plastics), the type of CLA isomer is crucial for their beneficial effects on physiological properties. In particular two isomers have been known for their health effects, viz. c9,t11 and t10,c12, while recent research indicates that t9,t11 CLA also exerts beneficial health effects [4]. Today, CLAs are synthesized in free fatty acid form from vegetable oils rich in linoleic acid using soluble base catalysts [5]. Besides the ecological drawbacks, competitive hydrolysis of the ester linkages is the major limitation of the commercial process.

This contribution presents the direct production of CLAs over Ru supported on zeolites [6]. Ru/Cs-USY (USY = ultrastable Y zeolite) having a Si/Al ratio of 40 was identified as the most active and selective catalyst for isomerisation of methyl linoleate to CLA at 165 °C. Interestingly, no hydrogen pre-treatment of the catalyst or addition of H-donors is required to achieve industrially relevant isomerisation productivities. Moreover, the biologically most active CLA isomers, viz. c9,t11, t10,c12 and t9,t11, were the main products, especially at low catalyst concentration. Catalyst characterization with CO-chemisorption, EXAFS measurements, TEM analysis and TPO, reveals highly dispersed RuO₂ species in Ru/Cs-USY(40). It is assumed that such clusters in reaction conditions are transformed into highly dispersed Ru metal clusters via a reaction of autoxidation of methyl linoleate by Ru-O. Finally, the Ru/USY(40) catalyst was also tested in the isomerization of pure vegetable oils [7]. Because of the particular synthesis procedure, extra mesopores are created in the USY support facilitating transport of the bulky triglyceride molecules to the active centers of the catalyst. As an example, the isomerization of safflower oil at 180 °C under N₂, yielded after 2 hours 75 mg CLA/g oil with a very high specific yield, viz. 377 g(CLA)/(g(metal).h), pointing to a very efficient process. The level of the desirable c9,t11 and t10,c12 isomers at this point was almost 55 mg CLA/g oil. Moreover, as no H₂ or another H-donor is used in the catalytic process, almost no hydrogenation was observed and only very low amounts of undersirable C18:1 trans were analyzed in the product mixture.

[1] a) T.F. Bradley, US 2350583, 1944; b) R.T. Sleeter, US 5719301, 1998 [2] Lu, Y., Larock, R.C., *ChemSusChem* 2, 136 (2009). [3] a) Bhattacharya, A. et al., *J. Nutr. Biochem.* 17, 789 (2006); b) Pariza, M.W. et al., *Progress in Lipid Research* 40, 283 (2001). [4] a) Coakley, M. et al., *Nutr. Cancer* 56, 95 (2006); b) Lee, Y., Vanden Heuvel, J.P., *J. Nutr. Biochem.* 21, 490 (2010); c) Ecker, J. et al., *Biochem. Biophys. Res. Co.*, 388, 660 (2009). [5] a) Saebo, A. et al., US 6410761 B1 (2002); b) Westfechtel, A. et al., US 20060106238 A1 (2006). [6] Philippaerts, A. et al. (submitted). [7] Philippaerts, A. et al. (submitted).

Catalytic hydrogenolysis of glycerol with in situ production of hydrogen

Stijn Van de Vyver¹, Els D'Hondt¹, Stuart Turner², Gustaaf Van Tendeloo², Lars Giebeler,³
Pierre Jacobs¹, Bert Sels¹,

¹K.U.Leuven, Heverlee, Belgium; ² University of Antwerp, Antwerpen, Belgium; ³Leibniz-Institute for Solid State and Materials Research, Dresden, Germany
stijn.vandevyver@biw.kuleuven.be

Hydrogenolysis of glycerol, considered as an ample platform chemical for future biorefinery processes, is a promising catalytic pathway for the direct production of 1,2-propanediol (PDO). Whereas the present industrial route involves hydrolysis of propylene oxide, crude glycerol of renewable origin seems to be an attractive source for sustainable future PDO production. Regrettably, current investigations imply the need of expensive bio- or petrochemically derived hydrogen. The innovative aspect of the catalytic system discussed here is the use of in situ produced hydrogen as a second reagent, allowing for the integrated catalytic transformation of glycerol into PDO without using an external H₂ supply.

In this poster presentation, we present a consistent reaction mechanism derived for the hydrogenolysis of glycerol in presence of NaY zeolite supported Pt catalysts [2]. The action of this bifunctional catalyst is based on consecutive dehydration of glycerol into hydroxyacetone and hydrogenation into PDO. Preliminary results under inert atmosphere are reported to yield up to 55 % PDO at 85 % conversion, ethanol, n-propanol and hydroxyacetone being the main side-products. Through a mechanistic study, the well-established aqueous-phase reforming of glycerol is identified as the source of H₂ for the hydrogenation of hydroxyacetone [3]. Also, the influence of the gaseous side-products is discussed and supported by quantitative GC analysis of the gas phase composition. In this approach, the proposed mechanistic pathways assume that initially formed CO₂ is at the origin of solution acidity and subsequently suitable zeolite Brønsted acidity.

The elucidation of the reaction mechanism offers a rational approach for the further optimization of the catalytic technology. More specifically, fine-tuning of the balance between the two catalytic functions as well as a suitable acid strength/concentration offers unique possibilities to control the product distribution [4].

References:

- [1] Sels, B.F., D'Hondt, E. and Jacobs, P.A. (eds. G. Centi and R.A. van Santen), *Catalysis for Renewables*, Wiley-VCH, Weinheim (2007) pp. 223–256.
- [2] D'Hondt, E., Van de Vyver, S., Sels, B.F. and Jacobs, P.A., *Chem. Commun.* (2008) 6011.
- [3] Cortright, R.D., Davda, R.R. and Dumesic, J.A., *Nature* 418 (2002) 964.
- [4] Van de Vyver, S., D'Hondt, E., Sels, B.F. and Jacobs, P.A., *Stud. Surf. Sci. Catal.* 175 (2010) 771.

A New Biomedical Materials Platform Based on Natural Macrolactones

Inge van der Meulen, Erik Gubbels, Rob Duchateau, Cor E Koning, Andreas Heise,
Eindhoven University of Technology, Eindhoven, Netherlands
i.v.d.meulen@tue.nl

In this research a range of macrocyclic lactones are randomly (co)polymerized using chemical as well as enzymatic ring opening polymerization in order to develop new polyesters with suitable properties for all kind of applications. Using these simple polymerization techniques a new platform based on unsaturated macrolactones is created. By tuning different aspects of the polymer and the polymerization, properties, for example degradability, porosity, crystallinity and mechanical properties, of the obtained polyesters can be tuned to different needs.

Alpha olefins from fatty acids

Frits van der Klis, Jérôme Le Nôtre, Rolf Blaauw, Jacco van Haveren, Daan S. van Es,
Wageningen UR Food & Biobased Research, Business Unit Biobased Products,
Wageningen, The Netherlands
rolf.blaauw@wur.nl

Bio-based internally unsaturated long chain hydrocarbons, obtained from unsaturated fatty acids, can serve as feedstock for the production of linear alpha olefins (LAO's) via ethenolysis. Currently, LAO's are produced petrochemically, and serve as starting materials for e.g. detergents and plastics (LLDPE).

Since the decarboxylation products of unsaturated fatty acids are not commercially available, we have previously prepared these materials by means of stoichiometric oxidative decarboxylation [1]. Here we report our preliminary results on ethenolysis using a series of commercially available metathesis catalysts. Both high conversions and high selectivities towards the desired LAO's were obtained.

[1] F. van der Klis, M.H. van den Hoorn, R. Blaauw, J. van Haveren, D.S. van Es, Eur. J. Lipid Sci. Technol., (accepted for publication).

Oxidation of tensidic alcohols to their corresponding carboxylic acids via Au-based catalysts

Katharina Heidkamp¹, Ulf Prüße¹, Klaus-Dieter Vorlop¹, Nicolle Schwarz²

¹Johann Heinrich von Thünen-Institut (vTI), Braunschweig, Germany; ² Clariant Produkte (Deutschland) GmbH, Germany
katharina.heidkamp@vti.bund.de

The production of detergents has always been one of the main uses of vegetable fats and oils in the area of non-food-applications. Detergents are widely-used in various applications concerning everyday life, such as household cleaning agents, personal-care products, paints, polymers, pharmaceuticals, mining and oil recovery. The worldwide production of synthetic surfactants amounts to 7.2 million tonnes per year. However, numerous production processes include the use of ecologically questionable reagents. In addition to that several currently used processes lead to by-products which impair product quality. Thus, intricate refining is needed.[1]

So, for ecological and economical reasons, these outdated processes need to be replaced by a new environmentally sound fundamental technology.

Our research group is first to develop and employ mono- and bimetallic Au-catalysts for the aqueous-phase oxidation of tensidic alcohols to their corresponding carboxylic acid. For this purpose, fatty alcohol ethoxylates - the second largest class of detergents – are used as the first model system.

Several preparation methods, catalyst supports and Au-Pt-ratios (for bimetallic catalysts) were screened with two model compounds: a lauryl ethoxylate and a methyl ethoxylate. For both model compounds monometallic Au-catalysts featured a selectivity of > 99 % to the carboxylic acid. Maintaining total selectivity, the activity could be increased significantly by using bimetallic Au-Pt-catalysts on ceria.[2] Thus, for comparable reaction conditions our optimized catalyst was 130 times as active as a Pt-catalyst from patent literature.[3]

The experiments were carried out at elevated pressures (1,5 -10 bar) in thermostatted stainless steel autoclaves at constant pH (9 -11). Variation of reaction parameters and kinetic studies revealed a dependency of the activity on temperature (80 – 130 °C), oxygen pressure, pH-value and educt concentration (5 – 80 %) – all of which do not affect the selectivity.

Under standard reaction conditions (8 bar O₂, 80 °C, pH 11, 100 mmol/kg substrate, 1000 rpm) the optimized catalyst was tested for the oxidation of several fatty alcohol ethoxylates with varying alkyl and ethylene oxide chain lengths. An aryl ethoxylate was used as well. These experiments showed that the activity of the oxidation reaction is dependent on both the water solubility and the size of the substrate molecule. For all compounds the optimized catalyst featured a selectivity of > 99 %.

References:

[1] Patent DE 102 17 208 A1

[2] Patent DE 102007017179 A1

[3] Patent DE 34 46 561 A1

Catalytic oxidation of fatty alcohol ethoxylates in a trickle-bed reactor

Mehmet Aytemir, Ulf Prüße, Klaus-Dieter Vorlop, Nicolle Schwarz

¹Johann Heinrich von Thünen-Institut (vTI), Braunschweig, Germany; ² Clariant Produkte (Deutschland) GmbH, Germany
mehmet.aytemir@vti.bund.de

Fatty alcohol ethoxylates as well as their oxidation products represent two important classes of detergents: non-ionic and anionic tensides. The goal of our research is to conduct a continuous catalytic selective oxidation of two model compounds (methyl ethoxylate, lauryl ethoxylate). Therefore a trickle-bed reactor was designed for his challenging three-phase reaction.

This reactor provides a fixed bed volume of 15 mL for a supported catalyst. The entire system is insulated and may be operated at temperatures up to 100 °C and pressures up to 24 bar. It was employed for the testing of self-developed Au-Pt-catalysts supported on ceria.

The optimized catalyst features a good activity and a very high selectivity (>99 %) for both model substances at high conversions in the reactor system. In a continuous run with PEG M 1000 (methyl ethoxylate) kinetic studies were conducted by varying process parameters such as temperature, pressure and catalyst/substrate ratios. This experiment also indicated a good long-term stability of the catalyst.

Continuous transesterification of glycerol with diethyl carbonate using supported hydrotalcites as catalysts

Mayra G. Álvarez¹, Martina Plíšková¹, Anna M. Segarra¹,
Françesc Medina¹, François Figueras²

¹Department d'Enginyeria Química, Universitat Rovira i Virgili, Tarragona, Spain

²Institut de Recherches sur la Catalyse du CNRS, Villeurbanne, France

mayra.garcia@urv.cat

A great number of publications have been reported highlighting different procedures for glycerol valorisation. [1] Valuable chemicals can be obtained from glycerol via oxidation, esterification, etherification, acetalisation, dehydrogenation, polymerisation and so on. Glycerol carbonate and its esters are interesting derivatives of glycerol. They are relatively new materials in the chemical industry and, due to their properties (low toxicity, low flammability and low vapour pressure) have great potential as new component in gas-separation membranes, non-volatile solvents for dyes, lacquers, pharmaceuticals, detergents, adhesives, cosmetics, and biolubricants, [2] as well as for the synthesis of new functionalized polymers such as polyglycerol. [3]

Recently, we have shown that Mg/Al mixed oxides and its rehydrated form hydrotalcite (HT) are efficient and reusable catalysts for the transesterification reaction being able to replace homogeneous catalysts, such as K₂CO₃. [4] These studies were performed in batch reactor and using the catalyst in powder form. However, in order to study the capability of these kinds of catalysts using a continuous reactor the catalyst must be supported to gain mechanical stability. In this sense, controlled grain size particles of α - and γ -Al₂O₃ were used as supports for the synthesis of Mg/Al hydrotalcites by impregnation-combustion of Mg and Al precursor salts. After calcination and rehydration, dispersed HT-Al₂O₃ catalysts with Brønsted basic sites were obtained. These supported catalysts were used in the synthesis of glycerol carbonates by transesterification of glycerol and diethyl carbonate in order to obtain a green, efficient and selective process involving the use of a continuous system.

Calcined and rehydrated supported catalysts were efficient catalysts for this continuous process showing total glycerol conversion. The obtained products were glycerol carbonate (GC) and glycerol dicarbonate (GDC). The type of basic sites (Lewis or Brønsted) has a strong influence on the activity. Thus, catalysts that showed Brønsted basicity (rehydrated catalysts) had better performance than calcined ones that showed mainly Lewis basic sites. Furthermore, the selectivity to the products is also related to the type of basic sites. Brønsted sites favour the formation of GDC at expenses of GC.

References

- [1] Y. Zheng, X. Chen and Y. Shen, *Chem. Rev.*, **108** (2008) 5253.
- [2] D. Hérault, A. Eggers, A. Strube and J. Reinhard, DE101108855A1 (2002).
- [3] G. Rokicki, P. Rakoczy, P. Parzuchowski and M. Sobiecki, *Green Chem.*, **7** (2005) 529.
- [4] M.G. Álvarez, A.M. Segarra, S. Contreras, J.E. Sueiras, F. Medina and F. Figueras, *Chem. Eng. J.*, **161** (2010) 340.

Shape-memory polyurethanes synthesized from castor oil derivatived polyols via metathesis

E. del Río¹; G. Lligadas¹, V. Cádiz¹; M. Galiá¹; J. C. Ronda¹; M. A. R. Meier²

¹Dept. of Analytical and Organic Chemistry, Rovira i Virgili University, Tarragona Spain.

²KIT, Institute of Organic Chemistry, Karlsruhe, Germany

enrique.delrio@urv.cat

The utilization of renewable feedstocks is an important issue for a sustainable development due to the depletion of the fossil resources. Plant oils are one of the most important renewable resources for the chemical industry due to the available amount, its quality and the versatility of their transformations.¹ As important as the feedstocks is the efficiency of the chemical processes in order to avoid or minimize the impact in the environment. For this purpose the development and optimization of the catalytic systems is needed. In this way, the inherent double-bond functionality of the vegetable oils can be exploited for several efficient catalytic transformations through olefin metathesis.² However, the sustainable development not only is limited in finding renewable substitutes to those materials synthesized from fossil resources but also improving their properties. Multifunctional materials are those that combine different characteristics in order to multiply their applicability. Thus, together with the potential bio-degradability and bio-compatibility of the vegetable oilbased materials, the shape-memory effect increases the importance and the number of applications of those materials.³

The present work describes the synthesis of two families of polyols using metathesis chemistry. These polyols are based on undecenoic acid and glycerol derivatives. The first family of polyols was obtained by ADMET polymerization of 1,3-diundecenyl-glycerol monomer using undecenol as chain stopper. The second family of polyols was synthesized by ATMET polymerization of glyceryltriundecenoate with undecenol as chain stopper. These polyols were reacted with MDI to yield two series of polyurethanes that were characterized by infrared spectroscopy, differential scanning calorimetry (DSC), thermogravimetric analysis (TGA), and thermodynamic mechanical analysis (DMA). Some of these polyurethanes showed shape-memory effect which was also investigated.

¹ Meier, M. A. R.; Metzger, J. O.; Schubert, U. S. *Chem Soc Rev* 2007, 36, 1788–1802.

² Mutlu, H.; Montero de Espinosa, L.; Meier, M. A. R. *Chem Soc Rev* 2011, DOI: 10.1039/B924852H.

³ Lendlein, A.; Langer, R. *Science* 2002, 296, 1673-1676.

Dimethyl 1,19-nonadecandioate – a key compound to bio-based monomers

G. Walther¹, J. Deutsch¹, A. Martin¹, F.-E. Baumann², D. Fridag³, A. Köckritz¹
¹Leibniz-Institut für Katalyse e. V. an der Universität Rostock, Rostock, Germany
²Evonik Degussa GmbH, High Performance Polymers, Marl, Germany
³Evonik Oxeno GmbH, Marl, Germany
angela.koeckritz@catalysis.de

Introduction

Vegetable oils and fatty acids or esters may provide interesting feedstocks for the synthesis of long-chained aliphatic α,ω -substituted monomers needed for production of polymers such as polyamides, polyesters or polyurethanes. The challenge to be mastered is the selective conversion to linear monomers; synthetic methods are scarce in respect thereof. Recently, a catalytic conversion of methyl oleate to dimethyl 1,19-nonadecandioate (DND) was presented [1]. This method was evaluated for the synthesis of polyesters [2]. Our approach includes the synthesis of DND directly from high oleic sunflower oil (HOSO), its use as a key intermediate for selective preparation of the respective diacid, diol and the new diamine and a sophisticated reprocessing to obtain highly pure monomers suitable for polymer production.

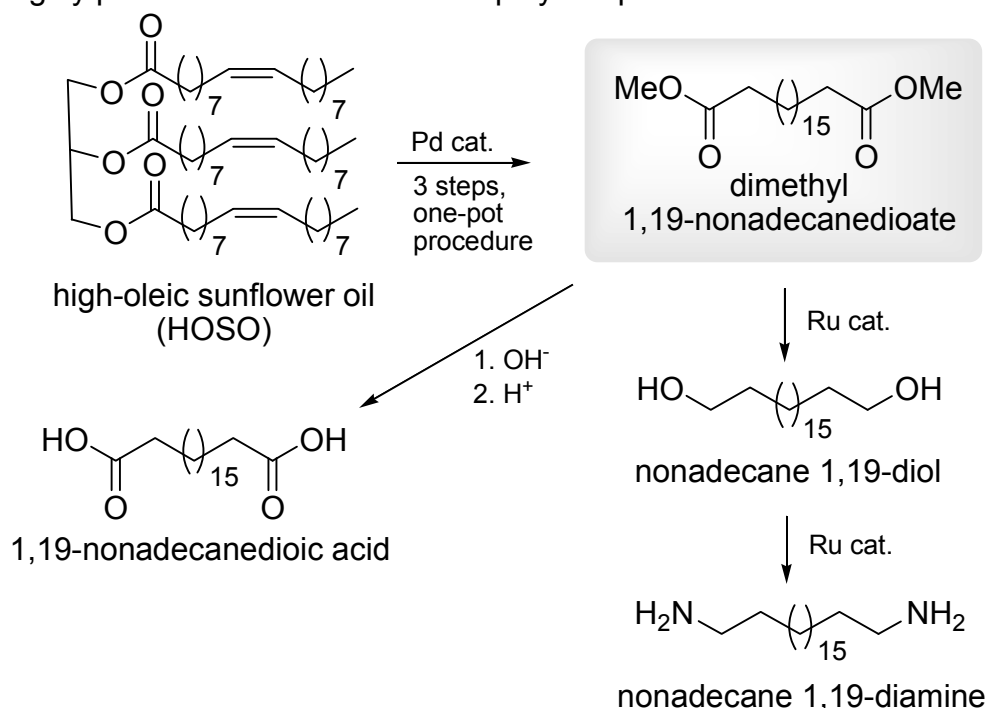

Experimental

HOSO was converted in the presence of a catalyst formed from $\text{Pd}(\text{OAc})_2$ and bis(di-*tert*-butylphosphinomethyl)-benzene (2.4 mol% Pd) as well as of methanesulfonic acid and MeOH to DND (80 °C, 30 bar CO, 32 h; 86 % yield). DND was hydrolyzed to the 1,19-diacid using aqueous KOH (98% yield). The 1,19-diol was obtained according to an adapted procedure [see 3] using [2-(Di-*tert*-butylphosphinomethyl)-6-(diethylaminomethyl)pyridine]carbonylchlorohydridoruthenium(II) as catalyst (98% yield). The direct amination

of the diol succeeded using conditions as described in [4] for simple alcohols with ammonia and carbonylchlorohydrido-(4,5-di-*i*-propylphosphinomethylacridino)ruthenium(II) as catalyst (68% yield).

Results

Surprisingly, DND was available by a direct reaction sequence in a one-pot procedure from HOSO, including the transesterification of the triglyceride to the methyl ester as well as the concurrent isomerization of the double bond to the ω -position and its methoxycarbonylation to the second ester group. The comparison with a two-stage procedure, where methyl oleate was isolated and further reacted, showed the advantage of the one-pot procedure. 86 % yield of DND could be isolated using 2.4 mol% of Pd compared to 68% in the two-stage process with the same amount of catalyst.

The suitability of DND as a well available key compound for the synthesis of other bifunctional C19-monomers was demonstrated exemplarily. The 1,19-diacid was obtained smoothly by alkaline hydrolysis. The scale of both the reactions, preparation of DND and diacid, could be upgraded up to a 12 l reactor.

The synthesis of the 1,19-diol was carried out via a homogeneously catalyzed hydrogenolysis using a Ru NNP pincer catalyst developed by Milstein and co-workers [3] under very mild reaction conditions. That reaction method may be an alternative, especially in regard to ecological requirements, to the application of complex hydrides used stoichiometrically, or to heterogeneous catalysts, which are not active till very high reaction temperature and H₂ pressure.

For the first time, the novel 1,19-diamine could be achieved by the direct amination of the respective diol with ammonia in the presence of another Ru PNP pincer catalyst. The observed yield of 68% is still not optimized, the remaining difference to 100% is guessed to be the secondary amine. Starting diol and intermediary amino alcohol were not found. By optimization of reaction condition, especially of reaction time, the yield to the desired diamine may be improved.

Summarizing, selective and technically feasible pathways to α,ω -functionalized monomers from HOSO, a well available natural product, were shown. They enable the production of polymers with new properties. Further work is in progress to develop much more active catalysts for these reactions.

[1] C. Jimenez-Rodriguez, G. R. Eastham, D. J. Cole-Hamilton, *Inorg. Chem. Commun.* **2005**, 8, 878.

[2] D. Quinzler, S. Mecking, *Angew. Chem.-Int. Ed.* **2010**, 49, 4306.

[3] J. Zhang, G. Leitus, Y. Ben-David, D. Milstein, *Angew. Chem. Int. Ed.* **2006**, 45, 1113.

[4] C. Gunanathan, D. Milstein, *Angew. Chem. Int. Ed.* **2008**, 47, 8661.

BIO-BASED POLYURETHANES FROM FATTY ACIDS

Aurélie Boyer, Vithoba D. Palaskar, Thomas Lebarbé, Lise Maisonneuve, Eric Cloutet,
Benoît Gadenne, Carine Alfos, Henri Cramail
Université de Bordeaux, France
maisonneuve.lise@gmail.com

The guiding principles for tomorrow's generation of advanced materials and processes are sustainability, industrial ecology, eco-efficiency and green chemistry. World-wide potential demands for replacing petroleum-derived raw materials with renewable ones are quite significant from the societal and environmental points of view. Among the various polymeric systems derived from renewable resources, polyurethanes (PU) are one of the most studied and exploited systems. Therefore, inexpensive vegetable-derived fats and oils bear a large potential to substitute currently used petrochemicals, thanks to their availability, sustainability and biodegradability. In this present work, two approaches are developed to synthesize more sustainable PU.

The first approach focuses on the design of well-defined diol diesters from methyl oleate. For instance, the amphiphilic properties and self-assembly of C18-PEG-C18 diols into hollow micelles make PU synthesis possible in aqueous dispersions without adding surfactants. [1]

The second approach of interest is to develop alternative methods for the preparation of PU avoiding the use of phosgene. One non-isocyanate strategy consists in the reaction between diamines and biscarbonates. The latter are obtained by reaction of fatty ester epoxides with CO₂. [2] Another non-isocyanate route is the PU synthesis through AB self-condensation. For the first time, novel acyl-azido / hydroxyl AB-type monomers from fatty acids have been synthesized using simple reaction steps and then readily polymerized.

References

- 1 A. Boyer, PhD Thesis, University Bordeaux 1, 2010.
- 2 A. Boyer, E. Cloutet, T. Tassaing, B. Gadenne, C. Alfos, H. Cramail, Green Chem. 2010, 12, 2205-2213.
- 3 D. V. Palaskar, A. Boyer, E. Cloutet, C. Alfos, H. Cramail, Biomacromolecules 2010, 11, 1202-1211.

EPOXIDIZED Plukenetia conophora oil BASED THIOL – ENE COATINGS

Cecilia Olufunke Akintayo, Michael A. R. Meier, KIT, Karlsruhe, Germany
fkintayo@yahoo.co.uk

The reaction of multifunctional thiols and enes is an established radical reaction and can lead to the rapid production of films and thermoset plastics with excellent mechanical and physical properties[1]. Plukenetia conophora based thiols and enes were synthesized through the Lewis acid catalysed ring opening reaction of epoxidized Plukenetia conophora oil with multifunctional thiols or hydroxyl functional allyl compounds, respectively. The functional group conversions were determined by Fourier transform infrared spectroscopy (FTIR) and ¹H NMR. Thiol-ene functionalized products were then reacted at different mole ratios and at different temperature (60, 90 and 100 °C) without initiators to form highly crosslinked polymers. The coating and thermal properties of the resulting polymers were studied and characterized using DMTA, DSC, TGA, and GPC.

Acknowledgement:

We thank the Alexander von Humboldt Foundation for a Georg Forster Research Fellowship for C.O. Akintayo.

1. C. E Hoyle, C. N Bowman, Angew. Chem. Int. 2010, 49, 1540-1573

Fermentative utilisation of crude glycerol from rapeseed oil hydrolysis for the production of dihydroxyacetone

S. Wiesen, N. Tippkötter, R. Ulber, Institute of Bioprocess Engineering, University of Kaiserslautern, Germany wiesen@mv.uni-kl.de

Within the project SynRg, founded by the Federal Ministry of Food, Agriculture and Consumer Protection (BMELV) and the Agency for Renewable Resources (FNR), project number 22022908, it is planned to establish new value chains from renewable resources to goods for industrial use, e.g. the utilization of modified fatty acids from rapeseed oil. The triglycerides in the plant oil are enzymatically hydrolyzed to glycerol and the corresponding fatty acids quantitatively by the enzyme lipase type VII from *Candida rugosa*. The resulting phases can be separated in a separatory funnel.

The crude glycerol can be used for whole cell biocatalysis to produce value added products. One product of glycerol fermentation is dihydroxyacetone (DHA), which is commonly used as a tanning agent in the cosmetics industry. Moreover, DHA serves as a versatile building block for the organic synthesis of a variety of fine chemicals. The microbial production of DHA is economically superior to the chemical process due to the rather expensive safety requirements of the chemical process. The industrial process of DHA production with *Gluconobacter oxydans* is being performed in the fed-batch operation mode at present in order to keep the substrate concentration below the inhibition level at all times. Growth experiments showed that, compared to other glycerol utilizing organisms, *G. oxydans* has shown itself very robust against the common inhibitory effect of fatty acids, that are present in trace amounts in the crude glycerol. Research about the effects of oleic acid on *Gluconobacter* growth have been done, experiments under addition of up to 0,65 g/l oleic acid showed that there is no negative impact on the growth of *Gluconobacter*. Furthermore, even higher DHA yields were achieved with crude glycerol from enzymatic hydrolysis, than with pure glycerol in the standard medium. Further research will be done on the yield enhancing influence of the crude glycerol feedstock.

Lowering the Boiling Curve of Biodiesel using Cross-metathesis

Rowena E. Montenegro, Michael A. R. Meier, KIT, Karlsruhe, Germany
winnie.montenegro@gmail.com

One of the challenges of today's plant oil-derived biodiesel is its almost constant boiling curve. An increasing and continuous curve with compounds boiling in the low as well as high temperature range is beneficial because it provides good fuel ignition and combustion in the cylinder of the engine. Here, we present the results of our investigation on the chemical modification of biodiesel applying a well-known catalytic reaction, namely olefin-metathesis. Self- and cross-metathesis reactions of rapeseed derived biodiesel with 1-hexene were carried out studying and screening ten different ruthenium catalysts at temperatures of 40 and 50°C and different catalyst loadings. Especially the cross-metathesis should lead to compounds of lower chain-length (and therefore lower molecular weight) with lower boiling points. After selection of the most active catalyst, a series of reactions were prepared wherein the concentration of the biodiesel was held constant, while hexene was varied from 0 to 1 equivalent. The samples were then analyzed by simulated distillation to determine their boiling curve range. Results revealed that as the hexene amount was increased, a more favorable distillation curve was observed since it generated a fairly good distribution of low to high molecular weight compounds, which in turn exhibited a nearly steady increasing distillation curve, more similar to that of a conventional diesel fuel.

Lipase-catalyzed Acylation of Microbial Sophorolipids

V. K. Recke¹, M. Gerlitzki², R. Hausmann², C. Syldatk², V. Wray³, S. Lang¹

¹Institute of Biochemistry and Biotechnology, TU Braunschweig; ² Technical Biology, KIT, Karlsruhe; ³Helmholtz Centre of Infection Research, Braunschweig, Germany
v.recke@tu-bs.de

Various microorganisms are able to produce biosurfactants with interesting molecular structures. Predominantly they are formed during growth on hydrophobic substrates such as sunflower oil. As for the major class of biosurfactants, glycolipids, they have an amphiphilic structure consisting of sugar molecules linked to aliphatic acid or alcohols. Because of these structural moieties they show good surface activity and have advantages (biodegradability, non-toxicity) compared to chemical detergents (Kang et al. 2009). Here we would like to modify naturally occurring microbial glycolipids, e.g., sophorolipids from *Candida bombicola* (Brakemeier et al. 1998) which are known since 1969. In the first experiment the decanoic acid was attached to a sophorolipid (SLE) using the lipase Novozym 435 from *C. antarctica* as catalyst. The second task was to attach an uncommon fatty acid such as 3-hydroxy decanoic acid which was isolated from *Pseudomonas spec.* cultivations (Fig. 1). As result of these two experiments we got monoacylation and diacylation, respectively, of the carbohydrate backbone. The new products of the two experiments were purified via medium pressure liquid chromatography (MPLC) and afterwards they were identified by NMR and MS. Additionally the new glycolipids should be characterized with view on their potential to lower the surface tension of aqueous systems and to inhibit microbial growth.

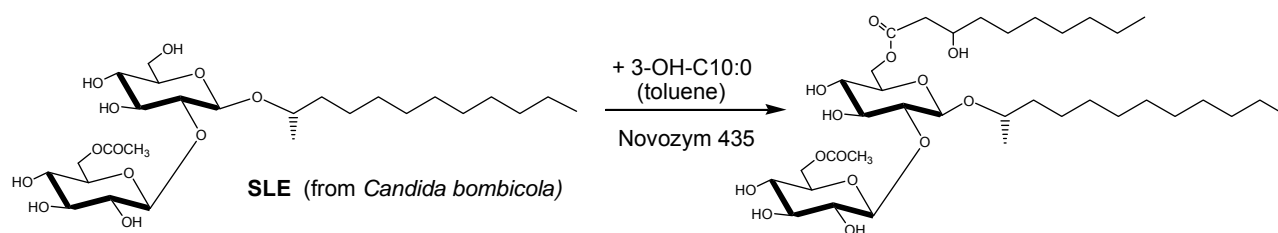

. : Figure 1. Lipase-catalyzed acylation of sophorose lipid SLE with 3-OH decanoic acid.

References:

- Kang S.-W, Kim, Y-B, Shin, J-D, Kim, E-K (2009) Enhanced biodegradation of hydrocarbons in soil by microbial biosurfactant, sophorolipid. *Appl Microbiol Biotechnol* 160: 780–790
- Brakemeier A, Wullbrandt D, Lang S (1998) *Candida bombicola*: production of novel alkylglycosides based on glucose/2-dodecanol. *Appl Microbiol Biotechnol* 50: 161-166.

RuO₄ Catalytic Oxidative Cleavage of Oleic Acid under Ultrasonic Irradiation

Nicolas Oget, Sandrine Rup, Eric Meux, Michèle Sindt, Michel Schneider, University of Metz, Metz, France
oget@univ-metz.fr

Chemical precipitation is the most common technology used to remove dissolved metals from industrial wastewater but generally, these chemical precipitation processes lead to sludge without any commercial or industrial values which are stored in specialized landfill. Previous works showed that sodium carboxylates can be used for the selective precipitation of metallic cations (Chemosphere 69 (2007) 763–768; J. Chem. Eng. Data, 50 (2005) 1833-1836).

The aim of this communication is (i) the oxidative cleavage of oleic acid to lead pelargonic acid and (ii) the using of sodium pelargonate as precipitant to perform selective precipitation of metallic cations.

The oxidative cleavage of oleic acid was realised under 20 KHz ultrasonic irradiation with the catalytic RuCl₃/NaIO₄. Associated with Aliquat® 336, this system allowed the free organic solvent oxidative cleavage (Tetrahedron Lett. 51 (2010) 3123–3126). However, the optimal mixture of solvents was H₂O/MeCN (1/1): azelaic and pelargonic acids were obtained in 30 min with 81% and 97% yields respectively (Ultrason. Sonochem. 16 (2009) 266–272).

Continuous Enzymatic Transesterification of Soybean Oil

Jiří Hetflejš¹, Stanislav Šabata¹, Jan Sýkora¹, Gabriela Kuncová¹ and Tomáš Vlček²

¹Institute of Chemical Process Fundamentals of the ASCR, v. v. i. Prague, Czech Republic

²Synpo, a.s., Pardubice, Czech Republic

tomas.vlcek@synpo.cz

Two transesterification processes of potential large scale application have been studied:

- a) continuous glycerolysis of soybean oil with the aim to produce a mixture of the glycerides to be used in the manufacture of alkydes and
- b) transesterification of the oil with trimethylolpropane, being of interest in view of the only so far reported synthesis based on the use of the methyl esters.

A heated packed bed reactor filled with the commercial enzyme catalyst Novozym 435 (immobilized *Candida antarctica* lipase) and connected to a preheated magnetically stirred reservoir was used for this purpose. The reaction mixture (containing substrate and reactant dissolved in t-butanol) was pumped upwards through the column. Optimum conditions were found by varying several process parameters (flow rate, reactant to substrate molar ratio, and temperature) and the product composition compared to that obtained in a stirred reactor.

Thus, an equilibrium composition (33.7 % monoglyceride (MG), 26.7 % diglyceride (DG) and 39.6% triglyceride (TG)) similar to that obtained by the chemical glycerolysis of soybean oil (240°C, NaOH as catalyst) was produced at 48 oC in 10 min reaction time, using glycerine (G) to oil (S) molar ratio = 2 and t-butanol (t-B) to S molar ratio= 4.

In a typical example, a continuous transesterification of soybean oil with trimethylolpropane (TMP) at TMP/S molar ratio = 2.5, t-B/S molar ratio = 33, 48 oC and 15 min residence time afforded a mixture consisting of 4 % of free fatty acids, 44.3 % of the monoesters (24.4 % 1-glyceride, 5 % 2-glyceride, 70.6 % mono ester of S with TMP), 41.6 % of the diesters (27.4 % 1,2-diglyceride, 49.5 % 1,3-diglyceride, 23,1 % diester of S with TMP), and 10 % TG.

The steady catalyst operation has been confirmed in 100 hour experiment. The product showed good stability at room temperature for 150 days.

Acknowledgement: This work was supported by the Ministry of Industry and Trade of the Czech republic through the project ENZALKYD (project ID: 1A-3TP1/108).

P38

Moving toward desymmetrization of a glycerol derivative

Gemma Villorbina, Marc Escribà, Jordi Eras, Mercè Balcells, Ramon Canela, University of Lleida, Lleida, Spain

gemmav@quimica.udl.cat

Putative approaches to the desymmetrization of 1,3-dichloro-2-propyl pivalate have been evaluated. This ester can be obtained from crude glycerol provided from a biodiesel industry. Most of the assayed reactions are highly regioselectives. Moreover, the desymmetric compounds prepared are putative precursors of medicaments and chiral ionic liquids.

Chemo-enzymatic epoxidation of fatty acids and triacylglycerides from various plant oils

Paula Carrillo, Fabian Haitz, Thomas Hirth, Steffen Rupp, Susanne Zibek, Fraunhofer IGB Stuttgart, Stuttgart, Germany

Fabian.Haitz@igb.fraunhofer.de

An important field in sustainable industrial chemistry is the development of new applications for renewable raw materials, e.g. plant fats and oils or lignocellulosic materials. Currently, vegetable oils make up the greatest proportion of renewable feedstocks consumed in chemical industry. One of the promising applications is the use of bifunctional derivatives as dicarboxylic acids (DCA), epoxidized triacylglycerides (ETAG) and epoxidized fatty acids (EFA) as precursors of polymer building block for bioplastics. In contrast to conventional plastics, bioplastics are polymers derived from renewable biomass sources.

The majority of industrial DCA, ETAG and EFA production for polyamide (PA), polyester (PE) and epoxy resins synthesis is still done via chemical synthesis out of fossil resources with harsh reaction conditions. Biotechnology provides novel biochemical approaches for long-chain DCA, ETAG and EFA synthesis that can provide an eco-efficient process alternative.

Unsaturated triacylglycerides and fatty acids are currently epoxidized on an industrial scale by the Prileshajev epoxidation reaction, in which a peracid is used for the oxygen transfer to the double bonds in the unsaturated fatty acid chain. The peracid is usually formed in situ from hydrogen peroxide and acetic or formic acid using a strong mineral acid or ion exchange resin as catalyst. The presence of strong acids in the reaction mixture is considered to cause undesired side reactions, leading via oxiran-ring opening to diols, hydroxyesters, estolides and other dimers. Alternatively, fatty epoxides can be produced in a milder and more selective process using enzymes like epoxidases, monooxidases or lipases. Most commonly a commercial immobilized preparation of *Candida antarctica* lipase B is used to catalyze the formation of peracid directly from fatty acid and hydrogen peroxide.

We studied commercially available enzymes as well as novel discovered enzymes towards their performance with different fatty acids and plant oils of various degree of unsaturation. Oleic acid, methyl oleate, linoleic acid, linolenic acid and various plant oils were epoxidized using an immobilized *Candida antarctica* lipase (Novozym® 435). We showed up to almost 100% conversion of these substrates to ETAG and EFA within a time scale of a few hours. The influence of substrate concentration, enzyme amount and hydrogen peroxide addition on the conversion was also studied. Almost complete conversion to the according epoxide in a solvent-free system was shown for methyl oleate at room temperature. In contrast a complete epoxidation of oleic acid was not possible without solvent addition at room temperature due to solidification of the reaction mixture. The conversion rate of different oils was also increased in case of solvent addition possibly due to a decreased viscosity and resulting reduction of mass transfer limitations.

Acknowledgement: The work was performed within the project Integrierte BioProduktion funded by BMELV (Bundesministerium für Ernährung, Landwirtschaft und Verbraucherschutz, Germany) and FNR (Fachagentur Nachwachsende Rohstoffe; FKZ 22027407).

Ruthenium Ruptures Rubber

Stefanie Wolf, Herbert Plenio, TU Darmstadt, Darmstadt, Germany

s.wolf@hrzpub.tu-darmstadt.de

The enforced shift from crude oil based chemistry to a chemistry relying on renewable resources has initiated vigorous efforts to explore alternatives – primarily plant based substitutes. Polyolefins, such as natural rubber have been neglected so far - despite the fact that the annual production of NR in 2007 amounts to 9.7 Mio t.[1] The high degree of stereoregularity of NR offers excellent chances for controlled polymer degradation by ethenolysis reaction which should lead to smaller isoprene oligomers with terminal double bonds. To find the optimum reaction conditions, we used the linear triterpene squalene as a model substrate for natural rubber. Using (NHC)(NHCewg)RuCl₂(indenylidene)[2] complexes catalyst loading of only 0.01 mol% [Ru] per double bond was found to be sufficient for the 75% conversion of squalene. The best catalysts for squalene ethenolysis were applied to the ethenolysis of natural rubber, several isoprene oligomers were isolated and characterized by NMR spectroscopy and HR-MS.

[1] A. Corma, S. Iborra, A. Velty, Chem. Rev. 2007, 107, 2411-2502.

[2] L. H. Peeck, H. Plenio, Organometallics 2010, 29, 2761-2768.

[3] S. Wolf, H. Plenio, Eur. Patent Application 2010, manuscript submitted for publication.

Living ROMP of partially renewable monomers

Hatice Mutlu^{1,2}, Michael A. R. Meier²

¹ Hochschule Emden/Leer, Emden, Germany; ² KIT, Karlsruhe, Germany

hatice.mutlu@student.kit.edu

The development of synthetic methods to prepare macromolecular architectures that contain functional groups is of significant interest. Functional poly(norbornene)s are of particular interest because of their unique physical and optic properties, such as high glass transition temperature, optical transparency and low birefringence.[1] Ring-opening metathesis polymerization (ROMP) is nowadays a well-established polymerization technique.[2,3] Both well-defined Schrock and Grubbs type initiators are suited for these purposes and allow for the polymerizations in a truly living manner.[4,5] We recently reported the ring-opening metathesis polymerization (ROMP) of fatty acid functionalized norbornenes using dichloro[1,3-bis(2,4,6-trimethylphenyl)-2-imidazolidinylidene](benzylidene)bis(3-bromopyridine)ruthenium(II) (Grubbs 3rd generation catalyst) at room temperature.[6] The investigated monomers were derived from fatty acids with different chain lengths (C6, C8, C10, C12, C14, C16, and C18) and therefore contributed to the development of more sustainable, biobased polymeric materials. Furthermore, grafting onto with different fatty acids was performed. First, ROMP has been used to produce well defined OH-group containing polymer backbones. Therefore, a hydroxy-functional monomer was first polymerized to the desired molecular weight. This functional poly(norbornene) precursor polymer was then reacted with fatty acid methyl esters (FAMEs) of different chain lengths. Moreover, unsaturated FAMEs as well as FAME mixtures directly obtained from plant oils were applied successfully. Thus, we derived partially renewable high-performance polymers with defined polymer architecture that allowed for the investigation of structure-property relationships, as will be discussed in this contribution.

[1] J. W. Feast, M. Gimeno, E. Khosravi, *J. Mol. Catal. A: Chem.* 2004, 213, 94.

[2] M. R. Buchmeiser, *Chem. Rev.* 2000, 100, 1565.

[3] A. Furstner, *Angew. Chem.* 2000, 112, 3140-3172; *Angew. Chem., Int. Ed.* 2000, 39, 3012.

[4] C. Slugovc, *Macromol. Rapid Commun.* 2004, 25, 1283.

[5] A. Leitgeb, J. Wappel, C. Slugovc, *Polymer* 2010, 51, 2927.

[6] H. Mutlu, M. A. R. Meier, *J. Polym. Sci. Part A: Polym. Chem.* 2010, 48, 5899.

ADMET polymerization of castor oil based aliphatic polycarbonates and polyester carbonates

Hatice Mutlu^{1,2}, Michael A. R. Meier²

¹ Hochschule Emden/Leer, Emden, Germany; ² KIT, Karlsruhe, Germany
hatice.mutlu@student.kit.edu

Polycarbonates are amorphous polymers with excellent material properties. They incorporate many attributes of metals, glasses and synthetics like transparency, rigidity, high impact resistance and heat-deflection temperature (up to 148 °C).[1] However, polycarbonates that possess such properties are chiefly derived from 4,4-isopropylidene diphenol (bisphenol A) and are regarded as non-biodegradable polymers. On the other hand, aliphatic polycarbonates possess an advantage of biodegradability, biocompatibility and low toxicity, which is useful for biomedical applications such as serving as the matrix in drug-delivery systems.[2,3] The synthesis of improved new aliphatic polycarbonates and more economically feasible processes would obviously increase the number of their applications. There are three major methods that are applicable to the synthesis of aliphatic polycarbonates: ring-opening polymerization of cyclic carbonates, copolymerization of epoxides with carbon dioxide and polycondensation of carbonic acid diesters and aliphatic diols. Our research uses olefin metathesis as an efficient catalytic method to polymerize α,ω difunctional fatty acid derivatives via acyclic diene metathesis (ADMET).[4] In this case we prepared renewable polycarbonates via ADMET of a castor oil derived carbonate monomer. By changing the monomer feed ratio of this new monomer with known renewable ester containing monomers, proportions of carbonate-to-ester repeating units in polymers were varied. By means of NMR, GPC, TGA and DSC, macromolecular structures and physical properties have been characterized for these aliphatic poly(ester carbonate)s.

[1] J. R. Fried, Polymer Science and Technology, Prentice Hall, 2003.

[2] U. Edlund, A.-C. Albertsson, S. K. Singh, I. Fogelberg, B. O. Lundgren, Biomaterials 2000, 21, 945-955.

[3] G. T. Rodeheaver, T. A. Powell, J. G. Thacker, R. F. Edlich, Am. J. Surg. 1987, 154, 544-547.

[4] H. Mutlu, L. Montero de Espinosa, M. A. R. Meier, Chem. Soc. Rev. 2011, DOI: 10.1039/B924852H

Renewable Polyethylene mimics derived from castor oilOğuz Türünc^{1,2}, Michael A. R. Meier²¹ Hochschule Emden/Leer, Emden, Germany; ² KIT, Karlsruhe, Germany
oguz.turunc@student.kit.edu

Considering recent attempts to produce plastic materials from renewable resources, there has been a great number of reports on the syntheses of carbohydrate- and plant oil-based polymers.[1] Although many of these polymers are biodegradable and this is a desirable property for certain applications, in some cases non-degradable polymers are needed for long-term use purposes. Polyethylenes are one of the important classes of materials that have already taken their places in our daily life. On the other hand, their production relies on fossil resources. Therefore, within this contribution, we discuss synthetic route from fatty acids to polyethylene in order to establish renewable routes for this important class of polymers.

Both ADMET and thiol-ene reactions have been shown to be excellent methods in order to functionalize and(or) polymerize fatty acid derived monomers.[2,3] Considering the mechanisms of these reactions, 10-undecenoic acid, a castor oil derived platform chemical, is perfectly suited to be used as a renewable monomer.[4] Therefore we applied thiol-ene click and ADMET polymerization reactions for the polymerization of a fatty acid based monomer in order to establish an alternative pathway towards the synthesis of renewable polyethylenes from plant oil. Moreover, the properties of the polymers derived thereof will be compared to that of commercially available products. In summary, we will show that both olefin-metathesis and thiol-ene click chemistry are very versatile tools for the polymerization of the fatty acid derivatives and thus contribute to the application possibilities of plant oils.

References:

- [1] L. Montero de Espinosa and M.A.R. Meier, *Eur. Polym. J.*, 2011, DOI: 10.1016/j.eurpolymj.2010.11.020.
- [2] H. Mutlu, L. Montero de Espinosa, M. A. R. Meier. *Chem. Soc. Rev.*, 2011, 40, 1404–1445.
- [3] O. Türünc, M. A. R. Meier. *Macromol. Rapid Commun.*, 2010, 31, 1822–1826.
- [4] O. Türünc and M.A.R. Meier. *Green Chem.*, 2011, 13, 314-320.

P44

**Novel Materials From Renewables via Small Building Blocks with
Considerable Potential: O-acylated Hydroxy Carboxylic Acid
Anhydrides – Selected Highlights**

Karsten Lange, Bernd Jakob, Hans Josef Altenbach, Manfred Schneider, Rachid Ihizane,
Sukhendu Nandi, Bergische Universität Wuppertal, Germany
klange@uni-wuppertal.de

Hydroxy carboxylic acids like malic, tartaric and citric acid can readily be converted almost quantitatively into the title compounds by reacting them with fatty acid chlorides or fatty acid anhydrides. These intermediates are excellent electrophiles for ring opening reactions with a broad variety of nucleophiles – also frequently from renewable resources - such as alcohols, carbohydrates, amines, amino acids and amino sugars. A wide variety of novel surface active combination products are obtained. It turned out, that many of them are useful as surfactants emulsifiers, thickener and/or gelators for applications in cosmetics and food additives as well. This poster highlights several different combination products with a various range of characteristics.

Methylesters of Linseed oil Fatty Acids Modified with Dicyclopentadiene as Raw Material for Synthesis of Unsaturated Polyester Resins

L. Víšek¹, M. Pokorný¹, T. Vlček²

¹ VÚOS, a.s., Rybitví 296, 533 54 Rybitví, Czech Republic

² SYNPO, a.s., S. K. Neumanna 1316, 532 07

tomas.vlcek@synpo.cz

The aim of this work was to develop a technology for synthesis of novel bio-based unsaturated polyester resin with maximum content of methylesters of fatty acids. Methylesters of fatty acids are due to current overproduction of biodiesel easily available renewable raw material suitable for production of variety of polymeric materials.

In this work we studied the potential applicability of methylesters of linseed oil fatty acids (FAME) in production of unsaturated polyesters. The model polyester resin standard was made of 133,6 g propyleneglycol, 311,1 g diethylene glycol, 375,4 g phtalanhydride and 172,7 g maleic anhydride and dissolved in styrene to make 60 % solution. In order to increase the reactivity of the unsaturated fatty acids of linseed oil towards radical copolymerization with styrene we first modified the methylesters (161,8 g) with dicyclopentadiene (DCPD)(58,2 g) by means of Diels-Alder addition. We conducted the reaction at 160 °C and atmospheric pressure for 7 h. The GC-MS analysis confirmed that the concentration of the adduct of methylesters of linseed oil fatty acids with cyclopentadiene (CPD) in the product was 20 %.

We found that the adduct FAME-CPD can't be used as environmentally friendly reactive diluent in unsaturated polyester resins, because it is immiscible with toxic styrene. Since the adduct is monofunctional, it acts as polymeric chain growth stopper and can't be used as reactive compound added to the reaction mixture at the beginning of the polyester synthesis. Therefore we decided to apply the adduct of FAME and CPD at the end of the model resin synthesis when the acid number declined to about 30 mg KOH/g. We continued running the polycondensation reaction until the acid value dropped back to 30 mg KOH/g. Then we make a 60 % solution of the unsaturated polyester in styrene and cured the systems first 24 h at room temperature, then 24 h at 55 °C and post cured 2 h at 120 °C. We initiated the curing with 1 wt. % of dilauroyl peroxide added to the resin solution.

The thermo-mechanical analysis revealed that increasing concentration of the FAME-CPD adduct up to 19 wt. % decreases tensile strength from 56,2 to 3,4 MPa, while elongation at break increases from 0,88 to 57,0 %. Flexural strength decreases from 90,1 to 0,41 Mpa, heat deflection temperature decreased from 49,8 to 44,1 °C and glass transition temperature decreased from 73,0 to 31,6 °C. These results are in agreement with expected plastification effect of the long fatty acid chains decreasing the polymeric network density.

The developed bio-based unsaturated polyester resin containing up to 19 wt. % of methylesters of linseed oil fatty acids modified with DCPD can be applied due to the specific properties as putty for car body refinishing.

Acknowledgement: This work was supported by project No. SP/3g3/85/07 sponsored by the Ministry of Environment of the Czech Republic.

Hydrothermal cracking of unsaturated fatty acids

Sarah Endisch, Gerd Unkelbach, Rainer Schweppe
 Fraunhofer Institut für Chemische Technologie (ICT), 76327 Pfinztal, Germany
Sarah.Endisch@ict.fraunhofer.de

Rising commodity prices and the growing scarcity of fossil resources lead to an increased interest in renewable resources and synthetic strategies for the production of basic chemicals from them. For change from petrochemical to plant based feedstocks the optimization of the entire value chain is necessary. Research from the seed to the finished product is necessary.

The Fraunhofer Institute for Chemical Technology deals among others with a "green way" for the conversion of vegetable fatty acids, such as rapeseed oil with high oleic acid concentration (C18: 1) to dicarboxylic acids. In a one-step hydrothermal process unsaturated fatty acids are cleaved to mono- and dicarboxylic acids (see figure 1).

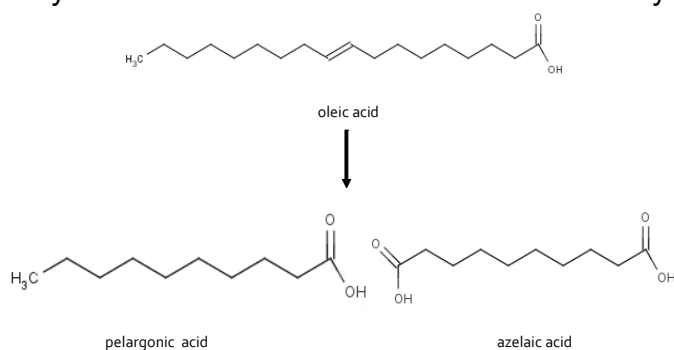

Figure 1: Cleavage of unsaturated fatty acid oleic acid

The experiments were performed in a continuous flow reactor system at temperatures up to 450°C and pressures up to 300 bars. Here, the influences of reaction parameters of temperature and residence time are explored on the cleavage products of the unsaturated fatty acids. By good selection of the reaction conditions the desired dicarboxylic compounds are produced by this method.

The obtained monomers can be purified by a high-temperature-rectification and further polymerized to biobased polymers.



Figure 2:
 Continuous flow reactor system at
 Fraunhofer ICT

We thank the Agency Nachwuchsendende Resources (FKZ 22023008) and the project partners in the research network SynRg.

List of participants

Dr. Habeebat Omolara Adubiaro

The Federal Polytechnic,
Ado Ekiti
Ikare Road, Ado-Ekiti P.M.B. 5351
234-30 Ado-Ekiti, Nigeria
hadubiaro@yahoo.com

Dr. Ibronke Adetolu Ajayi

University of Ibadan
AGBOWO 1234
IBADAN, Nigeria
frajayi@yahoo.com

Dr. Cecilia Olufunke Akintayo

Karlsruhe Institute of Technology (KIT)
Institute of Organic Chemistry,
Fritz-Haber-Weg 6
76131 Karlsruhe, Germany
fkintayo@yahoo.co.uk

Deewan Akram

(1) Jamia Millia Islamia (central
university), Delhi, India
(2) Jazan University, KSA
M.M.Zauhar Ali Marg, Materials
Research Lab, Dept. of Chemistry
M.M.Z.A.Marg
110025 New Delhi, India
deewanakram@gmail.com

Mayra Garcia-Alvarez

Rovira i Virgili University (URV)
Paisos Catalans 26
43007 Tarragona, Spain
mayra.garcia@urv.cat

Dr. Sukhprit Singh Arora

Department of Chemistry Guru Nanak
Dev University
143005 Amritsar, India
sukhprit@gmail.com

Mehmet Aytemir

Johann Heinrich von Thünen
Institut (vTI)
Institut für Agrartechnologie und
Biosystemtechnik
Bundesallee 50
38116 Braunschweig, Germany
mehmet.aytemir@vti.bund.de

Prof. Dr. Nuri Azbar

Ege University, Bioengineering
Department, Bornova Kampus
35100 Izmir, Turkey
nuriazbar@gmail.com

Zebib Bachar

ENSIACET-INRA/INPT Toulouse
4 allée Emile Monso BP 44362
31030 Toulouse, France
bachar.zebib@ensiacet.fr

Muhammad Baig

University of Birmingham
Edgbaston Chemical Engineering B15
2TT Birmingham, United Kingdom
m.n.baig@bham.ac.uk

Dr. Franz-Erich Baumann

Evonik-Degussa GmbH
Paul-Baumann-Str. 1
45764 Marl, Germany
margret.bueckers@evonik.com

Allan T. Bech

Danisco A/S
Edwin Rahrs Vej 38
8220 Brabrand, Denmark
allan.bech@danisco.com

Dr. Gesa Behnken

Bayer MaterialScience
Aktiengesellschaft BMS-CF-CD-NB-NT
Leverkusen, K 13, 038, Germany
gesa.behnken@bayer.com

Tanja Van Bergen-Brenkman

Croda
Buurtje 1
2802BE Gouda, Netherlands
tanja.van.bergen@croda.com

Avinash Bhadani

Guru Nanak Dev University
Department of Chemistry Amritsar
143005 Amritsar, India
avinashbhadani2003@yahoo.co.in

Dr. Ursula Biermann

University of Oldenburg
Carl-von-Ossietzky-Str. 9-11
26111 Oldenburg Germany
ursula.biermann@uni-oldenburg.de

Dr. Rolf Blaauw

Wageningen UR Food & Biobased
Research
Bornse Weilanden 9
6708 WG Wageningen,
The Netherlands
rolf.blaauw@wur.nl

Dr. Sylvain Caillol

ENSCM Ecole Normale 8
34296 Montpellier, France
sylvain.caillol@enscm.fr

Emrah Çakmakçı

Marmara University Fakülteler
34722 Istanbul, Turkey
emrah.cakmakci@marmara.edu.tr

Seong-Chea Chua

Aarhus University
Gustav Wieds Vej 10 1
8000 Aarhus C, Denmark
chua@mb.au.dk

Prof. Dr. David J. Cole-Hamilton

University of St. Andrews
School of Chemistry North Haugh
KY169ST St. Andrews, United Kingdom
djc@st-and.ac.uk

Marc von Czapiewski

University of Potsdam
Karl-Liebknecht-Straße 24-45
14476 Potsdam/Golm, Germany
marc_von_czapiewski@web.de

Louis Daniel

University of Groningen
Nijenborgh 4
9747AG Groningen, Netherlands
L.Daniel@rug.nl

Mr. Mathieu Delample

CNRS-LACCO
Avenue du recteur Pineau 40
86022 POITIERS, France
delamplemathieu@hotmail.fr

Manfred Diederich

Alberdingk Boley GmbH
Düsseldorfer Strasse 39
47829 Krefeld, Germany
m.diederich@alberdingk-boley.de

Dr. Markus Dierker

Cognis GmbH
Henkelstraße 67
40551 Düsseldorf, Germany
Markus.Dierker@cognis.com

Dr. Michael Dreja

Henkel AG & Co. KGaA
Henkelstrasse 67
40589 Düsseldorf, Germany
michael.dreja@henkel.com

Prof. Marc A Dubé

University of Ottawa
Louis Pasteur Pvt. 161
K1N6N5 Ottawa, Canada
Marc.Dube@uOttawa.ca

Christophe Duquenne

Cray Valley
RUE JACQUES TAFFANEL ALATA
60550 VERNEUIL-EN-HALATTE, France
christophe.duquenne@crayvalley.com

Sarah Endisch
Fraunhofer ICT
Joseph-von-Fraunhofer-Straße 7
76327 Pfinztal (Berghausen), Germany
sarah.endisch@ict.fraunhofer.de

Dr. Marco Eissen
Gymnasium Ganderkesee
Am Steinacker 12
27777 Ganderkesee, Germany
marco.eissen@web.de

Dr. Lucas Montero de Espinosa
Karlsruhe Institute of Technology (KIT)
Institute of Organic Chemistry,
Fritz-Haber-Weg 6
76131 Karlsruhe, Germany
lucas.espinosa@kit.edu

Yousef Fazli
Islamic Azad University - Arak Branch
Daneshgah Street 1
38135567 Arak Iran, Islamic Republic of
y_fazli@yahoo.com

Prof. Dr. Ivo Feussner
Georg-August-University
Dept. Plant Biochemistry
Justus-von-Liebig Weg 11
37077 Göttingen, Germany
ifeussn@uni-goettingen.de

Dr. Patrice A. Fokou
FH-Emden/Leer
Constantiaplatz 4
26723 Emden, Germany
patrice.fokou@fh-oow.de

Elena Gavrilova
Universita degli studi di Milano
CNR-ISTM
via Venezian 21
20133 Milan, Italy
elena.gavrilova@unimi.it

Prof. Dr. Harald Gröger
University of Erlangen-Nürnberg,
Department of Chemistry and Pharmacy
Henkestr. 42
91054 Erlangen, Germany
harald.groeger@chemie.uni-erlangen.de

Prof. Richard A Gross
Polytechnic Institute of NYU
Metrotech Center Six
11201 Brooklyn, United States
rgross@poly.edu

Mine Güngörmüşler
Ege University, Bornova Campus,
Bioengineering Department EBILTEM
35100 Izmir, Turkey
minegungormusler@gmail.com

Fabian Haitz
Fraunhofer IGB Stuttgart
Nobelstraße 12
70569 Stuttgart, Germany
Fabian.Haitz@igb.fraunhofer.de

Katharina Heidkamp
Johann Heinrich von Thünen-Institut (vTI)
Bundesallee 50
38116 Braunschweig, Germany
katharina.heidkamp@vti.bund.de

Ina Hein
KIT, IBLT, Section II: Technical Biology
Engler-Bunte-Ring 1
76131 Karlsruhe, Germany
ina.hein@kit.edu

Daniel Heinitz
Lohmann Gmbh & Co. KG
Irlicher Straße 55
56567 Neuwied, Germany
daniel.heinitz @lohmann-tapes.com

Dr. Norbert Holst
Fachagentur Nachwachsende Rohstoffe
Hofplatz 1
18276 Gülzow, Germany
n.holst@fnr.de

Dr. Rachid Ihizane
Universität Wuppertal
Gaußstr. 20
42119 Wuppertal, Germany
ihizane@uni-wuppertal.de

Dr. Bernd Jakob
Universität Wuppertal
Gaußstr. 20
42119 Wuppertal, Germany
bjakob@uni-wuppertal.de

Prof. Dr. Mats Johansson
KTH
Teknikringen 56-58
SE-100 44 Stockholm, Sweden
matskg@kth.se

Raman Kamboj
Guru Nanak Dev University
Department of Chemistry Amritsar
143005 Amritsar, India
kambyraman@gmail.com

Dr. James A. Kenar
NCAUR-ARS-USDA
North University 1815
61611 Peoria, United States
jim.kenar@ars.usda.gov

Dr. Angela K. Köckritz
Leibniz-Institut fuer Katalyse e.V. an der
Universitaet Rostock
Albert-Einstein-Str. 29a
18059 Rostock, Germany
angela.koeckritz@catalysis.de

Andreas Köhler
Sasol Solvents Germany GmbH
Römerstr. 733
47443 Moers, Germany
andreas.koehler@de.sasol.com

Dr. Christian König
BASF SE
Seckenheimer Strasse 23
68165 Mannheim, Germany
chris-koenig@gmx.de

Nicolai Kolb
Karlsruhe Institute of Technology (KIT)
Institute of Organic Chemistry,
Fritz-Haber-Weg 6
76131 Karlsruhe, Germany
nicolai.kolb@student.kit.edu

Dr. Oliver Kreye
Karlsruhe Institute of Technology (KIT)
Institute of Organic Chemistry,
Fritz-Haber-Weg 6
76131 Karlsruhe, Germany
oliver.kreye@kit.edu

Prof. Dr. Andreas Kuenkel
BASF SE
GKT/W & GVF/W - B001
67056 Ludwigshafen, Germany
andreas.kuenkel@basf.com

Ratna D. Kusumaningtyas
Gadjah Mada University
Jl Grafika 2
55281 Yogyakarta, Indonesia
dewinino@gmail.com

Dr. Gerard Lligadas
Rovira i Virgili University
C/ Marcel·IÀ- Domingo s/n
43007 Tarragona, Spain
gerard.lligadas@urv.cat

Dr. Karsten Lange
Universität Wuppertal
Gausstraße 20
42097 Wuppertal, Germany
klange@uni-wuppertal.de

Prof. Dr. Richard Larock
Iowa State University
2751 Gilman Hall 2751
50011-3111 Ames, United States
boone@iastate.edu

Prof. Dr. Walter Leitner
Institut für Technische und
Makromolekulare Chemie
RWTH Aachen
Worringerweg 1
52074 Aachen, Germany
leitner@itmc.rwth-aachen.de

Lise Maisonneuve
LCPO
Avenue Pey Berland 16
33607 PESSAC, France
maisonneuve.lise@gmail.com

Rolf Luther
FUCHS EUROPE SCHMIERSTOFFE
GMBH
Friesenheimer Str. 19
68169 Mannheim, Germany
rolf.luther@fuchs-europe.de

Wiebke Maassen
KIT - Karlsruhe Institute of Technology
Gotthard-Franz-Straße 3 (Geb. 50.31)
76131 Karlsruhe, Germany
wiebke.maassen@kit.edu

Susanne Mahnke
Karlsruhe Institute of Technology (KIT)
Institute of Organic Chemistry,
Fritz-Haber-Weg 6
76131 Karlsruhe, Germany
susanne.mahnke@gmx.net

Dr. Andreas Martin
Leibniz-Institut für Katalyse
R.-Willstätter-Str. 12
12489 Berlin Germany
andreas.martin@catalysis.de

Prof. Dr. Stefan Mecking
University of Konstanz
Chair of Chemical Materials Science
Universitätsstr. 10
78457 Konstanz, Germany
stefan.mecking@uni-konstanz.de

Prof. Dr. Michael A. R. Meier
Karlsruhe Institute of Technology (KIT)
Institute of Organic Chemistry,
Fritz-Haber-Weg 6
76131 Karlsruhe, Germany
m.a.r.meier@kit.edu

Prof. Dr. Jürgen O. Metzger
abiosus e.V.
Bloherfelder Str. 239
26129 Oldenburg, Germany
metzger@abiosus.org

Dr. Inge van der Meulen
Eindhoven University of Technology
Den Dolech 2
5612 AZ Eindhoven, The Netherlands
i.v.d.meulen@tue.nl

Prof. Dr. Helga Meyer
Hochschule Emden/Leer
Constantiaplatz 4
26723 Emden, Germany
helga.meyer@hs-emden-leer.de

Rowena E. Montenegro
Karlsruhe Institute of Technology (KIT)
Institute of Organic Chemistry,
Fritz-Haber-Weg 6
76131 Karlsruhe, Germany
rowena.montenegro@kit.edu

Zéphirin Mouloungui
INRA
Allée Emile Monso 4
31030 Toulouse Cedex 4, France
zephirin.mouloungui@ensiacet.fr

Hatice Mutlu
Karlsruhe Institute of Technology (KIT)
Institute of Organic Chemistry,
Fritz-Haber-Weg 6
76131 Karlsruhe, Germany
hatice.mutlu@student.kit.edu

Sukhendu Nandi
Bergische Universität Wuppertal
Gaußstraße 20
42119 Wuppertal, Germany
s.nandi@uni-wuppertal.de

Dr. Anke Neumann
Karlsruhe Institute of Technology (KIT)
Institut für Bio- und Lebensmitteltechnik
Bereich II: Technische Biologie (TeBi)
Engler-Bunte-Ring 1
76135 Karlsruhe, Germany
anke.neumann@kit.edu

Mr. Huy Hoang Nguyen
Oleon GmbH
Industriestraße 10
46446 Emmerich am Rhein, Germany
huyhoang.nguyen@oleon.com

Atze J. Nijenhuis
DSM Ahead
Urmonderbaan 22
6167 RD Geleen, Netherlands
atze.nijenhuis@dsm.com

Basam Nohra
LCA-ENSIACET
allee emile monso 4
31000 Toulouse, France
bassam.nohra@ensiacet.fr

Prof. Dr. Klaus F. Noweck
Universität Oldenburg
Sylter Str. 19
25541 Brunsbüttel, Germany
klaus@noweck.com

Mehmet Musa Özcan
Selçuk University
Selcuklu 1
42031 Konya, Turkey
mozcan@selcuk.edu.tr

Nicolas Oget
University Metz
Boulevard Arago
Metz Technopole, CP87811 1
57078 METZ, France
oget@univ-metz.fr

Dr. Henry Niyi Ogungbenle
University Of Ado-Ekiti
Ado-Ekiti PMB 5363
Ado -Ekiti 234360, Nigeria
httphenryo@yahoo.com

Dominik M. Ohlmann
TU Kaiserslautern
Erwin-Schrödinger-Straße 54
67663 Kaiserslautern, Germany
ohlmann@chemie.uni-kl.de

Dr. Frank-Martin Petrat
Evonik Degussa GmbH
Paul-Baumann-Straße 1
45772 Marl, Germany
frank-martin.petrat@evonik.com

Jürgen Pettrak
TU München
Lehrstuhl für Rohstoff- und
Energietechnologie
Schulgasse 16
94315 Straubing, Germany
juergen.pettrak@wzw.tum.de

Dr. H.J.F. (Erik) Philipse
Croda
PO Box 2
2800 AA Gouda, Netherlands
erik.philipse@croda.com

An Philippaerts
K.U.Leuven
Kasteelpark Arenberg 23
3001 Heverlee, Belgium
an.philippaerts@biw.kuleuven.be

Dr. Ulf Prüße
Johann Heinrich von Thünen-Institut (vTI)
Bundesallee 50
38116 Braunschweig, Germany
ulf.pruesse@vti.bund.de

Dr. Yann M. Raoul
SIA
Avenue George V 12
75008 Paris, France
y.raoul@prolea.com

Dr. Nicoletta M. Ravasio
CNR ISTM
via C. Golgi 19
20133 Milano, Italy
n.ravasio@istm.cnr.it

Verena Kerstin Recke
TU Braunschweig
Institut für Biochemie und Biotechnologie,
Abt. Biotechnologie
Spielmannstr. 7
38106 Braunschweig, Germany
v.recke@tu-bs.de

Dr. Enrique del Rio
University Rovira i Virgili
marcelli domingo
43007 Tarragona, Spain
enrique.delrio@urv.cat

Dr. Rita Rosenbaum
HOBUM Oleochemicals GmbH
Seehafenstraße 20
21079 Hamburg, Germany
pknolle@hobum.de

Somaieh Salehpour
University of Ottawa
280 Brittany Dr. 317
K1K4M4 Ottawa, Canada
somaieh.salehpour@gmail.com

Dr. Nadia Salih
School of Chemical Sciences & Food
Technology
Faculty of Science and Technology
Universiti Kebangsaan
Bangi 43600
006 Bangi, Malaysia
nadiaas@ukm.my

Mr. Jesus Santamaria
MERQUINSA
GRAN VIAL 17
08160 MONTMELO BARCELONA,
Spain
jsantamaria@merquinsa.com

Prof. Dr. Hans J. Schäfer
Universität Münster-Organisch-
Chemisches Institut
Correns-Str. 40
48149 Münster, Germany
schafeh@uni-muenster.de

Dr. Markus Scherer
Cognis GmbH
Henkelstr. 67
40589 Düsseldorf, Germany
markus.scherer@cognis.com

Dr. Christof Schmitz
Freudenberg Forschungsdienste
Hoehnerweg 2-4
69469 Weinheim, Germany
christof.schmitz@freudenberg.de

Prof. Manfred P. Schneider
Bergische Universität
Gauss-Strasse 20
42097 Wuppertal, Germany
schneid@uni-wuppertal.de

Ines Schulze
KIT - Technische Biologie
Engler-Bunte-Ring 1
76131 Karlsruhe, Germany
Ines.Schulze@kit.edu

Dr. Klaus Schurz
Süd-Chemie AG
Ostenrieder Str. 15
85368 Moosburg
klaus.schurz@sud-chemie.com

Ansgar Sehlinger
Karlsruhe Institute of Technology (KIT)
Institute of Organic Chemistry,
Fritz-Haber-Weg 6
76131 Karlsruhe, Germany
rockyansgar@gmail.com

Prof. Dr. Bert F. Sels
Katholieke Universiteit Leuven
Kasteelpark Arenberg 23
3001 Heverlee, Belgium
bert.sels@biw.kuleuven.be

Silviana Silviana
FVT-RUB
Universitätstrasse 150
44801 Bochum, Germany
silviana@fvt.rub.de

Florian Stempfle
Universität Konstanz
Hans-Sauerbruch Str. 3
78467 Konstanz, Germany
florian.stempfle@uni-konstanz.de

Oguz Türünç
Karlsruhe Institute of Technology (KIT)
Institute of Organic Chemistry,
Fritz-Haber-Weg 6
76131 Karlsruhe, Germany
oguz.turunc@student.kit.edu

Nils Tenhumberg
TU Dortmund
Emil-Figge-Strasse 66
44227 Dortmund, Germany
nils.tenhumberg@bci.uni-dortmund.de

Gerd Unkelbach
Fraunhofer ICT
Joseph-von-Fraunhofer-Strasse 7
76327 Pfinztal, Germany
gerd.unkelbach@ict.fraunhofer.de

Romain Valentin
INRA
EMILE MONSO 4
31030 TOULOUSE, France
romain.valentin@ensiacet.fr

Carla AC Vilela
University of Aveiro
CICECO/Chemistry Department
Campus de Santiago 0
3810-193 Aveiro, Portugal
cvilela@ua.pt

Dr. Gemma Villorbina
University of Lleida
Av. Alcalde Roure 191
25198 Lleida, Spain
gemmav@quimica.udl.cat

Dr. Tomas Vlcek
SYNPO, a.s.
S. K. Neumanna 1316
532 07 Pardubice, Czech Republic
tomas.vlcek@synpo.cz

Andreas J. Vorholt
TU Dortmund
Emil-Figge-Straße 66
44227 Dortmund, Germany
andreas.vorholt@bci.tu-dortmund.de

Prof. Dr. Dean C Webster
North Dakota State University
PO Box 6050 6050
58108 Fargo, ND, United States
dean.webster@ndsu.edu

Sebastian Wiesen
Bio Verfahrenstechnik
TU Kaiserslautern
Gottlieb-Daimler-Str. 44
67663 Kaiserslautern, Germany
wiesen@mv.uni-kl.de

Alfred Westfechtel
Emery Oleochemicals GmbH
Henkelstr. 67
40551 Düsseldorf, Germany
liane.momm@cognis-oleochemicals.com

Stefanie Wolf
TU Darmstadt, AK Plenio
Petersenstr 18
64287 Darmstadt, Germany
s.wolf@hrzpub.tu-darmstadt.de

Mehmet Ugur Yildiz
Istanbul university
Laleli 34
34200 Istanbul, Turkey
Uyildiz202@hotmail.com

Dr. Federica Zaccheria
ISTM CNR
Via Golgi 19
20133 Milano, Italy
f.zaccheria@istm.cnr.it

Dr. Aalbert Zwijnenburg
Johnson Matthey Chemicals GmbH
Wardstrasse 17
46446 Emmerich am Rhein, Germany
bart.zwijnenburg@matthey.com

Fernando Zuniga
Emery Oleochemicals GmbH
Henkelstr. 67
40551 Düsseldorf, Germany
liane.momm@emeryoleo.com

